

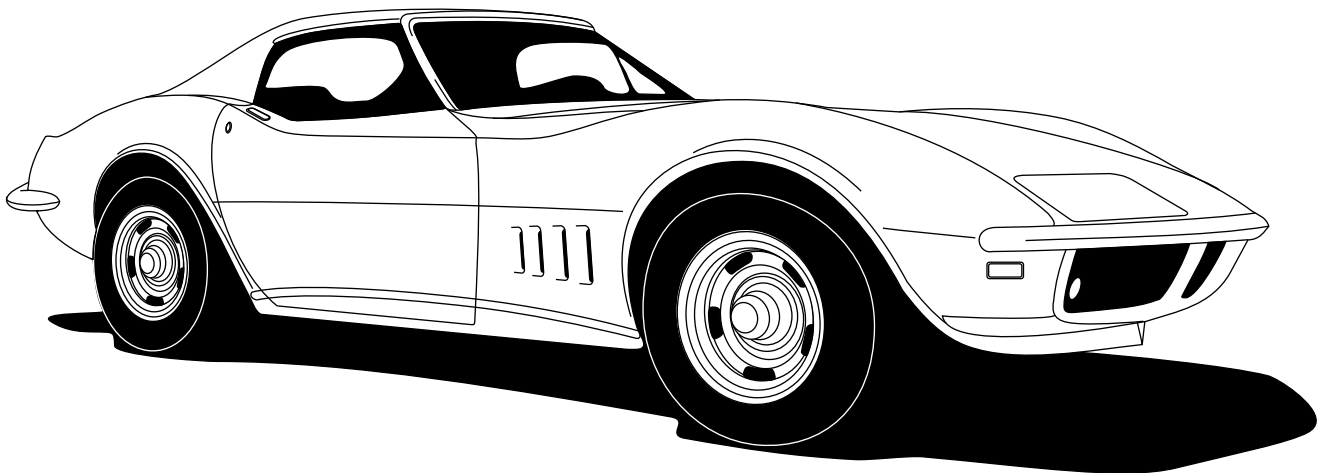

an ISO 9001:2015 Registered Company

1968 Chevrolet Corvette

with Factory Air
Evaporator Kit
(564168)



18865 Goll St. San Antonio, TX 78266

Phone: 800-862-6658

Sales: sales@vintageair.com

Tech Support: tech@vintageair.com

www.vintageair.com



www.vintageair.com

Table of Contents

Cover.....	1
Table of Contents.....	2
Packing List/Parts Disclaimer.....	3
Information Page.....	4
Wiring Notice.....	5
Engine Compartment Disassembly.....	6
Passenger Compartment Disassembly.....	7
Passenger Compartment Disassembly (Cont.), Fresh Air Cover Installation.....	8
Condenser Assembly & Installation, Compressor & Brackets, Pulleys.....	9
Defrost Duct Replacement.....	10
Passenger and Driver Side A/C Duct Hose Adapter Installation.....	11
Passenger Side Dash Modification.....	12
Center Louver Assembly.....	13
Firewall Modification, Evaporator Bracket Mounting Holes.....	14
Firewall Modification (Cont.), Evaporator Installation.....	15
Evaporator Installation (Cont.).....	16
Drain Hose Installation.....	17
Firewall Cover.....	18
A/C Hose Installation, Heater Hose & Heater Control Valve Installation, Lubricating O-rings.....	19
Hose Routing.....	20
Final Steps.....	21
Control Panel & Duct Hose Routing.....	22
Evaporator Hardline Installation.....	23
Wiring Diagram.....	24
Gen IV Wiring Connection Instructions.....	25
Operation of Controls.....	26
Troubleshooting Guide.....	27
Troubleshooting Guide (Cont.).....	28
Passenger Compartment Modification Templates.....	29
Firewall Modification Templates.....	30
Packing List.....	31



www.vintageair.com

Packing List: Evaporator Kit (564168)

No.	Qty.	Part No.	Description
1.	1	764172	Gen IV Evaporator Sub Case
2.	1	784170	Accessory Kit

**** Before beginning installation, open all packages and check contents of shipment. Please report any shortages directly to Vintage Air within 15 days. After 15 days, Vintage Air will not be responsible for missing or damaged items.**

1

Gen IV Evaporator
Sub Case
764172

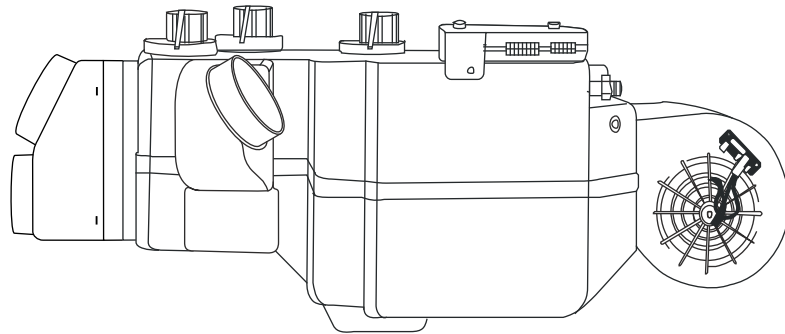

2

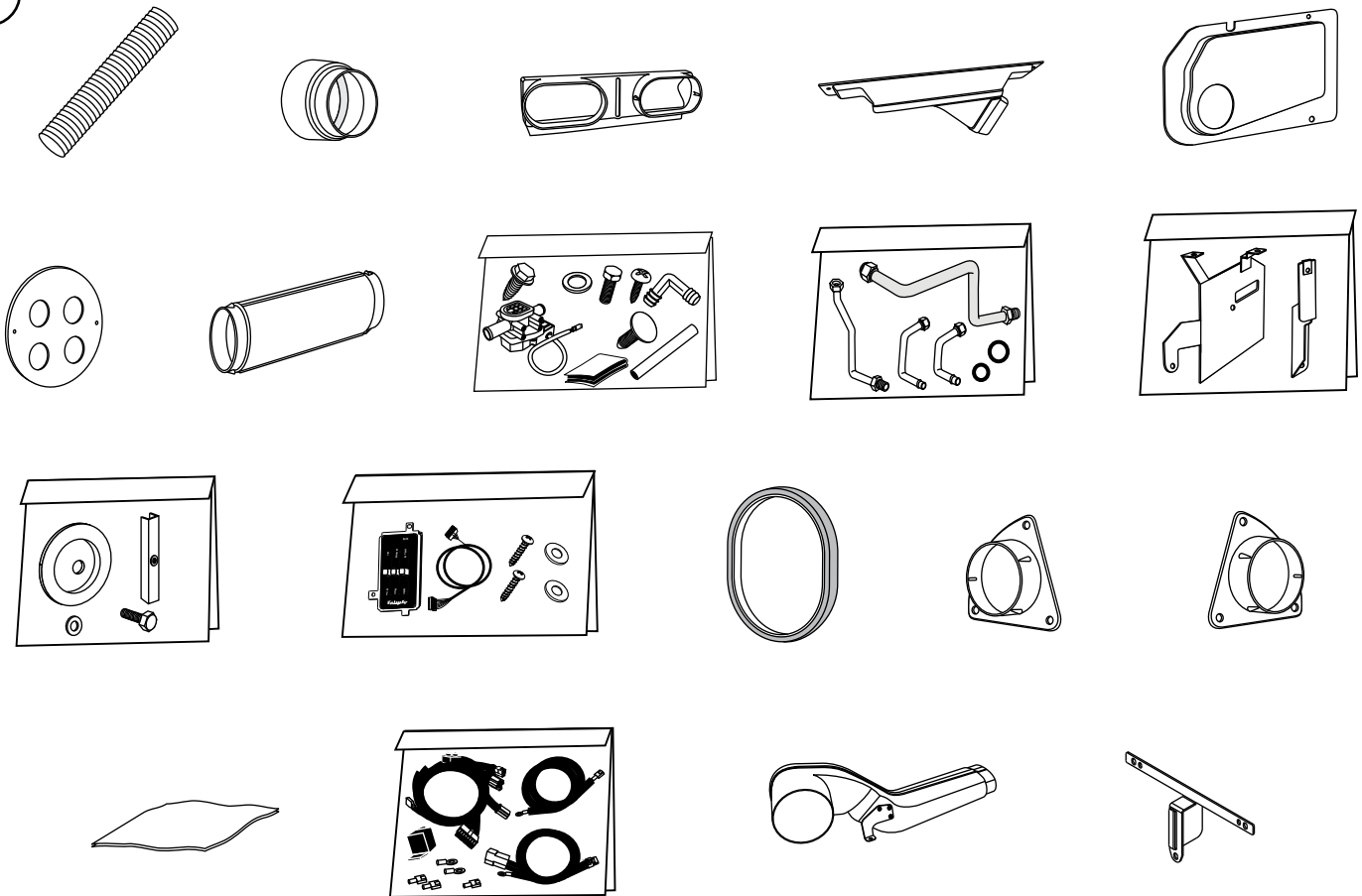

Accessory Kit
784170

NOTE: Images may not depict actual parts and quantities. Refer to packing list for actual parts and quantities.



www.vintageair.com

Important Notice—Please Read

For Maximum System Performance, Vintage Air Recommends the Following:

NOTE: Vintage Air systems are designed to operate with R134a refrigerant only. Use of any other refrigerant could damage your A/C system and/or vehicle, and possibly cause a fire, in addition to potentially voiding the warranties of the A/C system and its components.

Refrigerant Capacities:

Vintage Air System: 1.8 lbs. (28.8 oz.) or 816 grams of **R134a**, charged by weight with a quality charging station or scale. **NOTE: Use of the proper type and amount of refrigerant is critical to system operation and performance.**

Other Systems: Consult manufacturer's guidelines.

Lubricant Capacities:

New Vintage Air-Supplied Sanden Compressor: No additional oil needed (Compressor is shipped with proper oil charge).

All Other Compressors: Consult manufacturer (Some compressors are shipped dry and will need oil added).

Safety Switches

Your Vintage Air system is equipped with a binary pressure safety switch. A binary switch disengages the compressor clutch in cases of extreme low pressure conditions (refrigerant loss) or excessively high head pressure (406 PSI) to prevent compressor damage or hose rupture. A trinary switch combines Hi/Lo pressure protection with an electric fan operation signal at 254 PSI, and should be substituted for use with electric fans. Compressor safety switches are extremely important since an A/C system relies on refrigerant to circulate lubricant.

Service Info:

Protect Your Investment: Prior to assembly, it is critical that the compressor, evaporator, A/C hoses and fittings, hardlines, condenser and receiver/drier remain capped. Removing caps prior to assembly will allow moisture, insects and debris into the components, possibly leading to reduced performance and/or premature failure of your A/C system. This is especially important with the receiver/drier.

Additionally, when caps are removed for assembly, **BE CAREFUL!** Some components are shipped under pressure with dry nitrogen.

Evacuate the System for 35-45 Minutes: Ensure that system components (Drier, compressor, evaporator and condenser) are at a temperature of at least 85°F. On a cool day, the components can be heated with a heat gun *or* by running the engine with the heater on before evacuating. Leak check and charge to specifications.

Bolts Passing Through Cowl and/or Firewall:

To ensure a watertight seal between the passenger compartment and the vehicle exterior, for all bolts passing through the cowl and/or firewall, Vintage Air recommends coating the threads with silicone prior to installation.

Heater Hose (not included with this kit):

Heater hose may be purchased from Vintage Air (Part#31800-VUD) or your local parts retailer. Routing and required length will vary based on installer preference.



www.vintageair.com

Important Wiring Notice—Please Read

Some vehicles may have had some or all of their radio interference capacitors removed. There should be a capacitor found at each of the following locations:

- 1. On the positive terminal of the ignition coil.**
- 2. If there is a generator, on the armature terminal of the generator.**
- 3. If there is a generator, on the battery terminal of the voltage regulator.**

Most alternators have a capacitor installed internally to eliminate what is called “whining” as the engine is revved. If whining is heard in the radio, or just to be extra cautious, a radio interference capacitor can be added to the battery terminal of the alternator.

It is also important that the battery lead is in good shape and that the ground leads are not compromised. There should be a heavy ground from the battery to the engine block, and additional grounds to the body and chassis.

If these precautions are not observed, it is possible for voltage spikes to be present on the battery leads. These spikes come from ignition systems and charging systems, and from switching some of the vehicle’s other systems on and off. Modern computer-operated equipment can be sensitive to voltage spikes on the power leads, which can cause unexpected resets, strange behavior and/or permanent damage.

Vintage Air strives to harden our products against these types of electrical noise, but there is a point where a vehicle’s electrical system can be degraded so much that nothing can help.

Radio interference capacitors should be available at most auto and truck parts suppliers. They typically are cylindrical in shape, a little over an inch long and a little over a half inch in diameter, and they have a single lead coming from one end of the cylinder with a terminal on the end of the wire, as well as a mounting clip which is screwed into a good ground on the vehicle. The specific value of the capacitance is not too significant in comparison to ignition capacitors that are matched with the coil to reduce pitting of the points.

- Care must be taken, when installing the compressor lead, not to short it to ground. The compressor lead must not be connected to a condenser fan or to any other auxiliary device. Shorting to ground or connecting to a condenser fan or any other auxiliary device may damage wiring or the compressor relay, and/or cause a malfunction.
- When installing ground leads on Gen IV systems, the blower control ground and ECU ground must be connected directly to the negative battery post.
- For proper system operation, the heater control valve must be connected to the ECU.



www.vintageair.com

Engine Compartment Disassembly

NOTE: Before starting the installation, check the function of the vehicle (horn, lights, etc.) for proper operation, and study the instructions, illustrations, & diagrams.

Perform the Following:

1. Disconnect battery.
2. Remove hood to ease installation (retain).
3. Drain radiator.
4. Evacuate the A/C system (if necessary).
5. Remove OEM condenser and drier (discard).
6. Remove OEM A/C lines from compressor to evaporator (discard).
7. Remove OEM compressor and compressor bracket (discard).
8. Remove coolant overflow bottle (retain).
9. Remove OEM blower assembly and cover (discard).
10. Remove OEM evaporator and cover (discard).
11. Remove OEM A/C harness and vacuum harness (discard).
12. Install a 1 5/8" and 1 3/4" plug in the firewall as shown in Figure 1a, below.

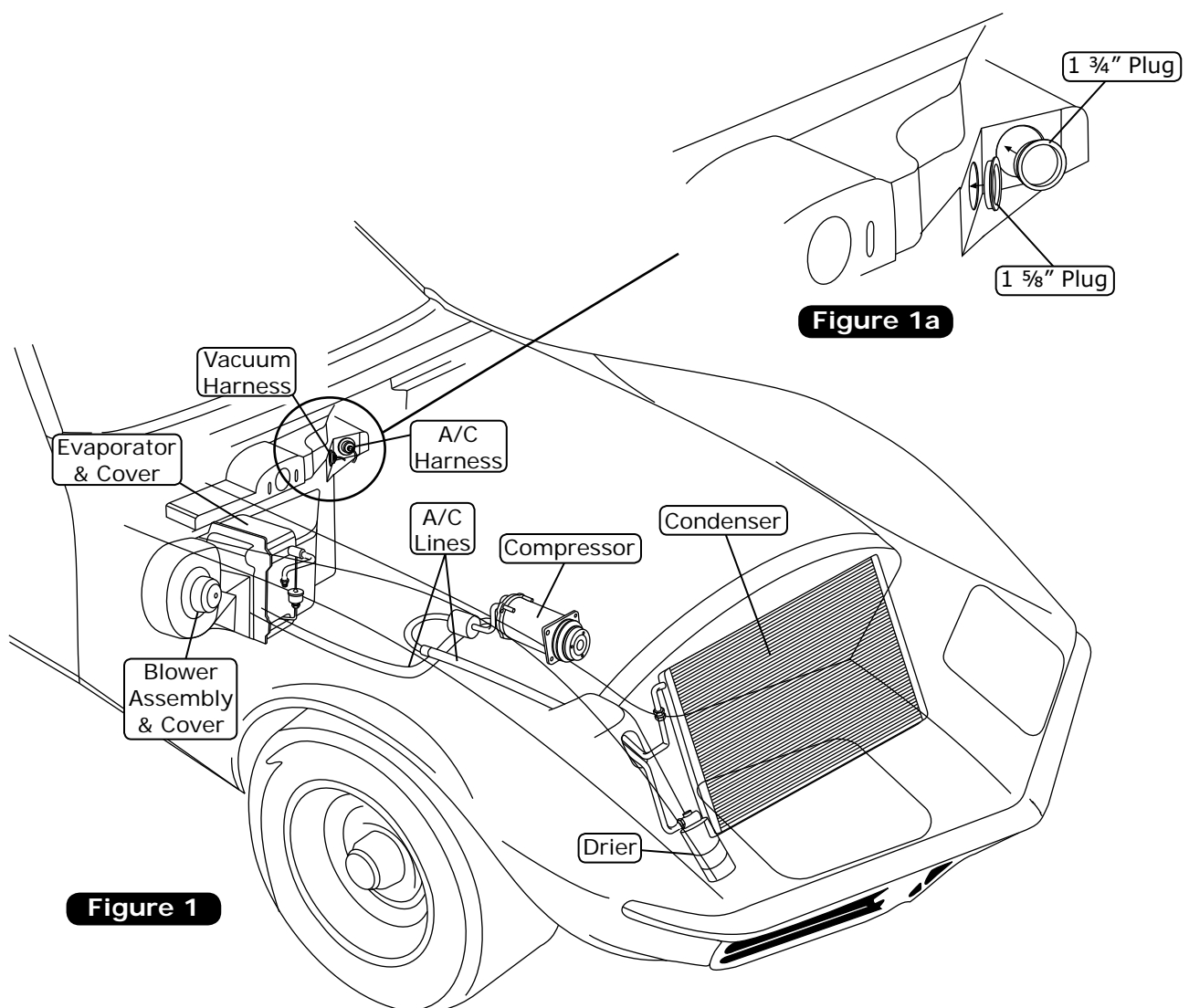



www.vintageair.com

Passenger Compartment Disassembly

Perform the Following:

1. Remove the passenger side dash (retain).
2. Disconnect the center dash (retain) and pull forward to remove the OEM A/C duct (discard duct).
3. Remove the OEM radio (retain).
4. Remove the OEM control panel (discard panel, retain mounting support bracket). Refer to control panel kit instruction for installation of new control panel.
5. Drop the steering column from the console.
6. Disconnect the driver side dash and pull forward.
7. Remove the passenger side, center and driver side A/C ducts as shown in Figure 3, below (discard).
8. Remove the floor heater duct as shown (discard).

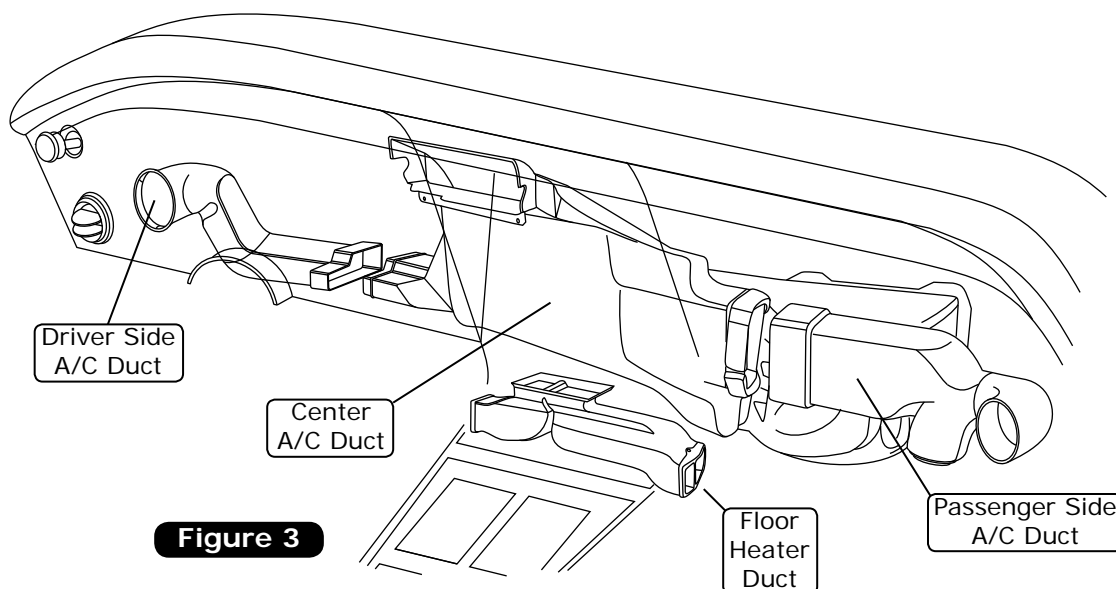
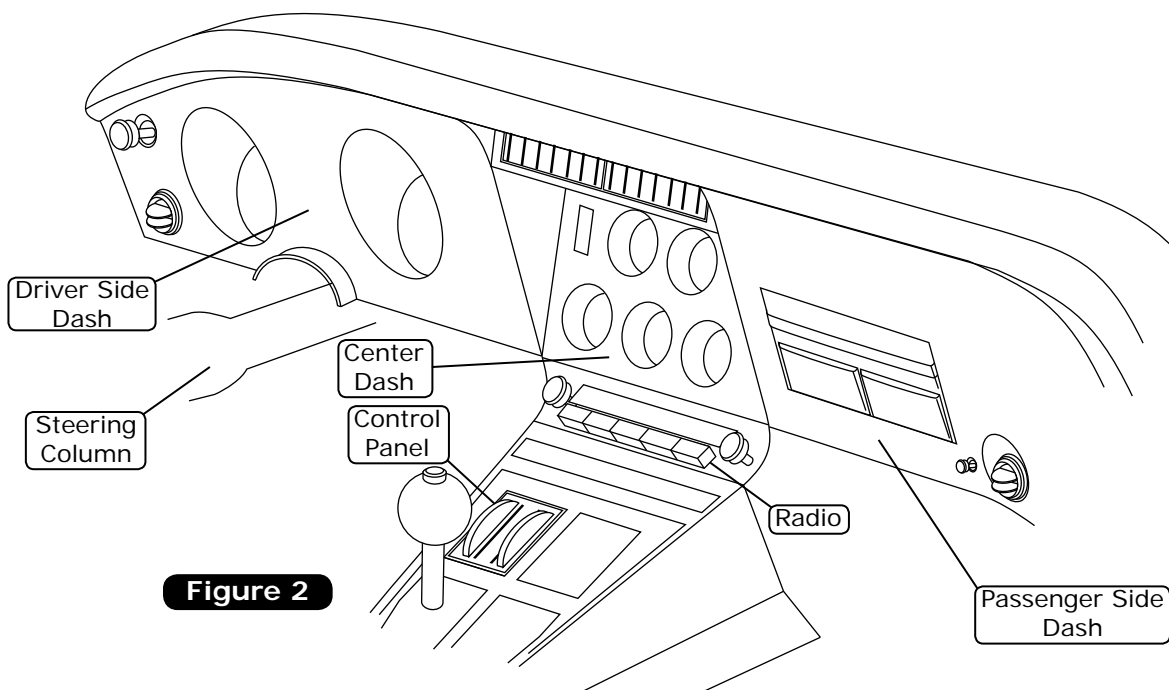



www.vintageair.com

Passenger Compartment Disassembly (Cont.)

Perform the Following:

1. Remove the OEM defrost duct (discard).
2. Remove the heater housing from under the dash.
3. Remove the kick panel vacuum control assembly (discard) (See Figure 4a, below).
4. Using (2) #8 x 1/2" pan head screws, install the kick panel fresh air cap as shown in Figure 4a, below. Prior to final installation, mark and drill (2) 1/8" holes using the kick panel fresh air cap as a template.

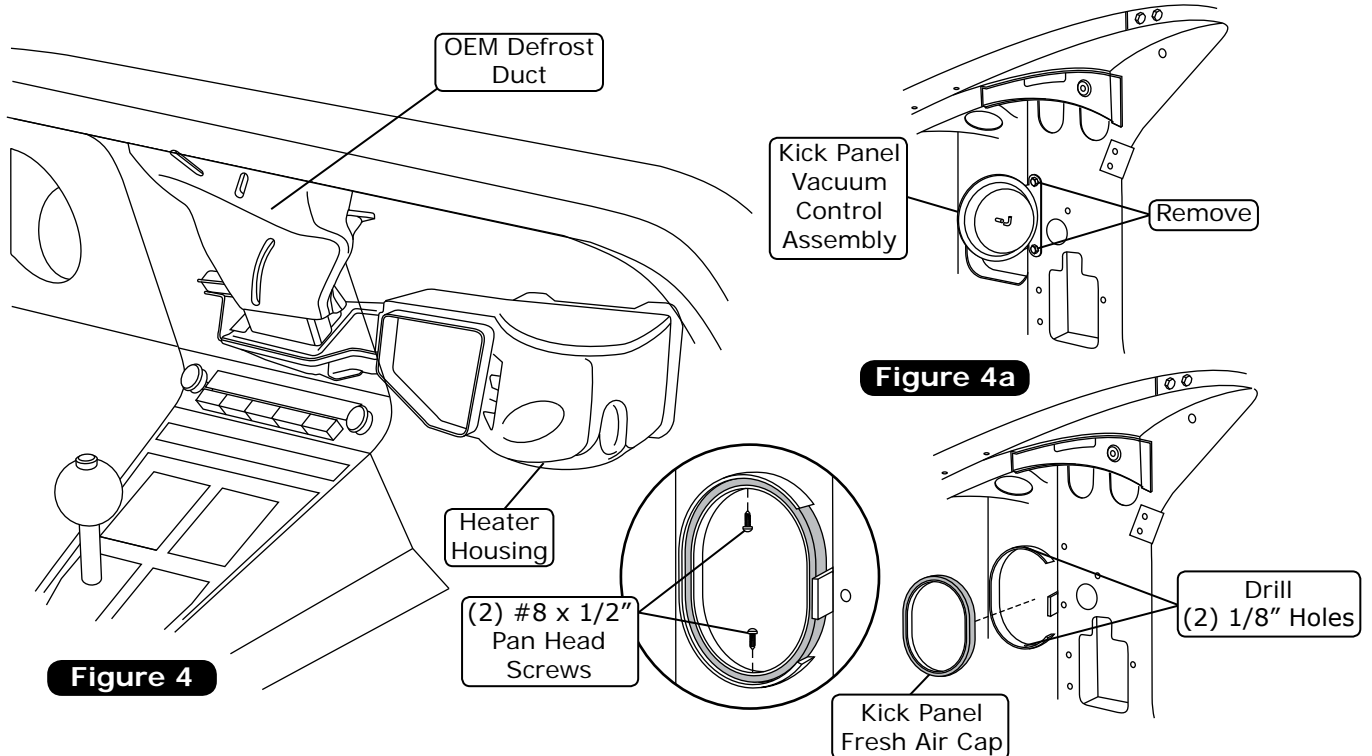

Fresh Air Cover Installation

1. Apply a 1/4" bead of silicone around the back side of the fresh air cap as shown in Figure 4b, below.
2. Attach the fresh air cap to the firewall using a 1/4-20 x 1" bolt and washer. See Figure 4b, below.

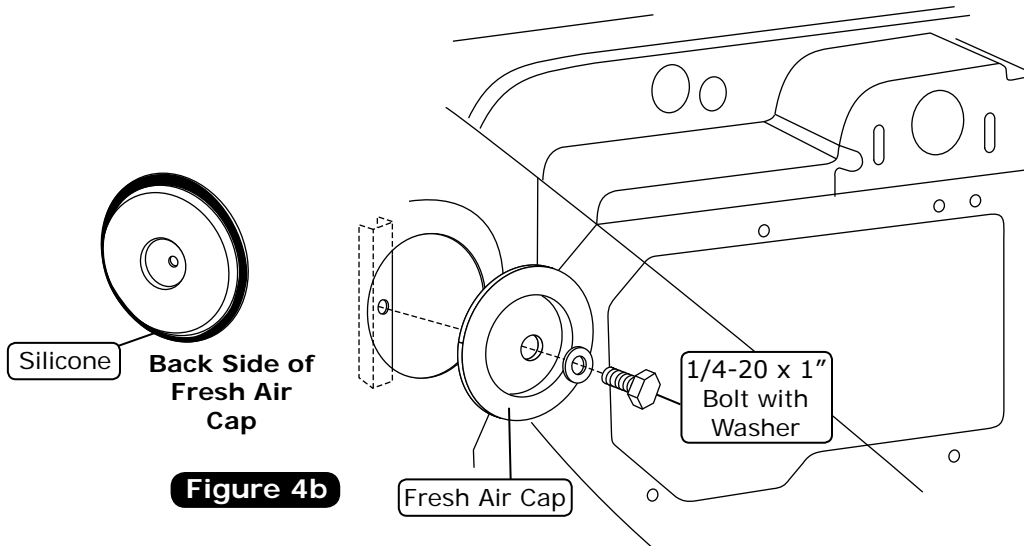



www.vintageair.com

Condenser Assembly & Installation

1. Refer to separate instructions included with the condenser kit to install the condenser. Refer to Figure 5, below, for condenser location.

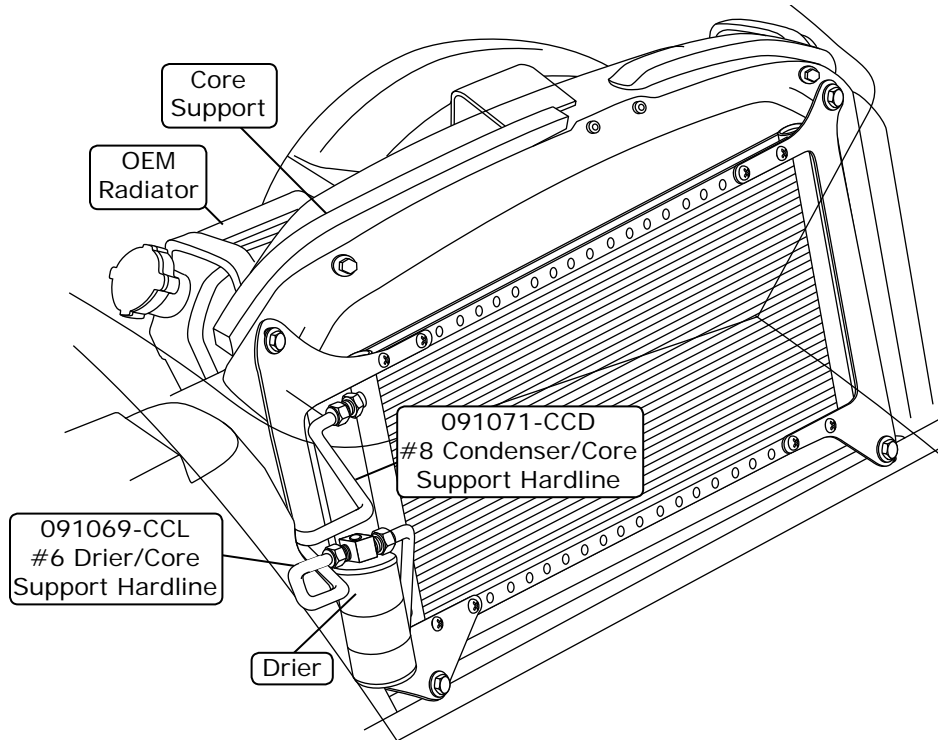

Figure 5

Compressor & Brackets

1. Refer to separate instructions included with the bracket kit to install the compressor bracket. Refer to Figure 6, below, for compressor mounting position.

Pulleys

1. In most instances, existing belt lengths will remain the same (See Figure 6, below). **NOTE: Belt routing may vary with different bracket sets. Always refer to instructions included with brackets.**

Pulleys available through Vintage Air:

Short Pump Small Block Chevy

22503-VCA - Water Pump Pulley (2-Groove)

22506-VCA - Crankshaft Pulley (2-Groove)
(with Power Steering, a 3-Groove Crank Pulley is Required)

22507-VCA - Crankshaft Pulley (3-Groove)

Short Pump Big Block Chevy

735002 - Water Pump Pulley (3-Groove)
Fits 1966-70 (5/8" Shaft)

735003 - Water Pump Pulley (3-Groove)
Fits 1971-74 (3/4" Shaft)

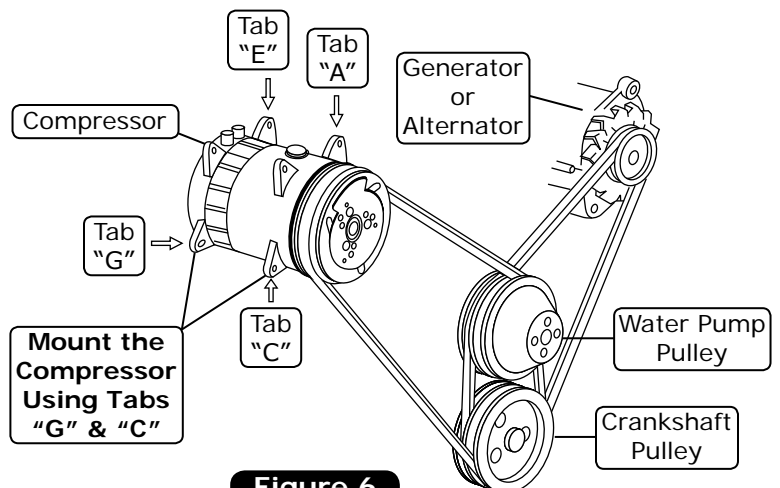

Figure 6



www.vintageair.com

Defrost Duct Replacement

1. Remove screws attaching the OEM defrost duct (retain (2) screws attaching the duct to the dash pad) (See Photo 1, below).
2. Remove remaining screws attaching the dash pad to the dash, and remove the dash pad from the vehicle (retain) (See Photo 1, below).
3. Place new defrost duct on the dash pad, in place of the OEM defrost duct (See Photo 2, below).
4. Attach using (2) screws removed in Step #1. Tighten and reinstall the dash pad using the OEM screws previously removed (See Photo 3, below).

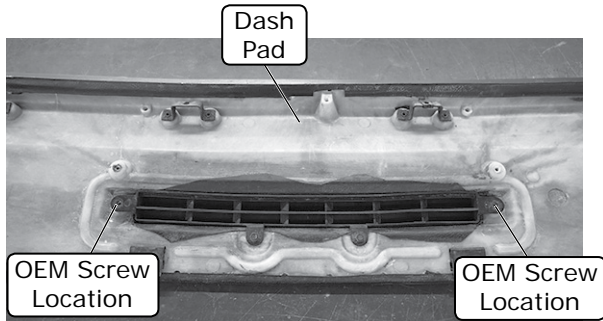

Photo 1

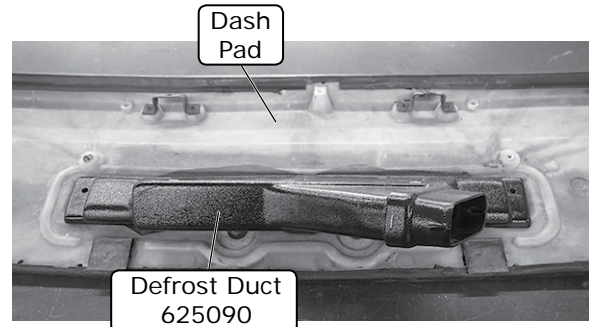

Photo 2

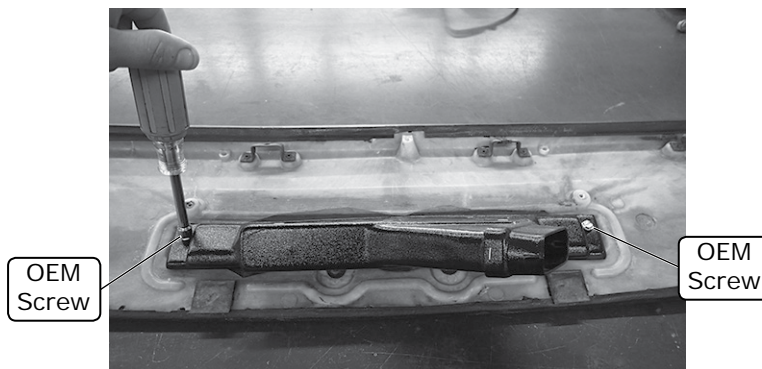

Photo 3



www.vintageair.com

Passenger and Driver Side A/C Duct Hose Adapter Installation

1. Remove the passenger and driver side vent adapters (discard) as shown in Figure 7, below. **NOTE: Retain mounting hardware.**
2. Install the inner and outer A/C duct hose adapters as shown in Figure 7, below. Use OEM screws to secure the adapters to the dash.
3. See Figure 8, below, for a completely assembled view of the A/C duct hose adapter.

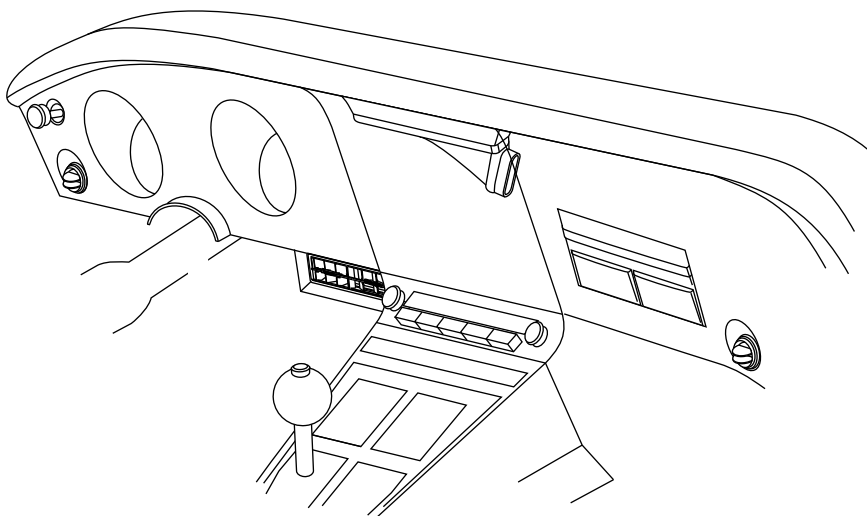
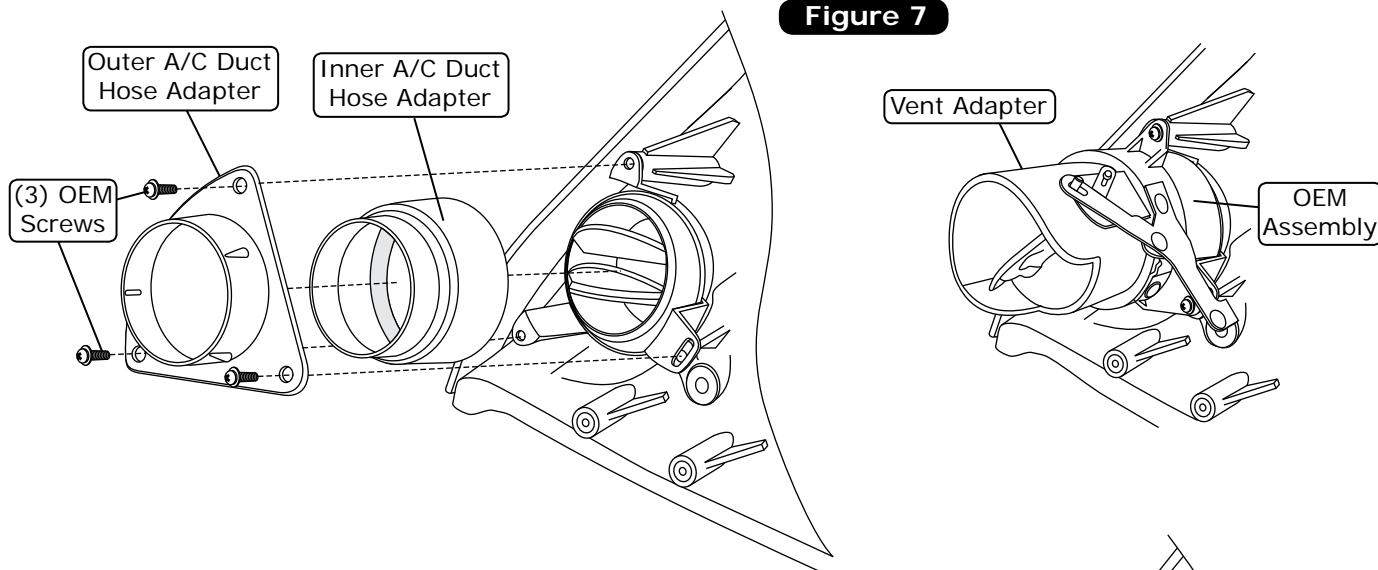
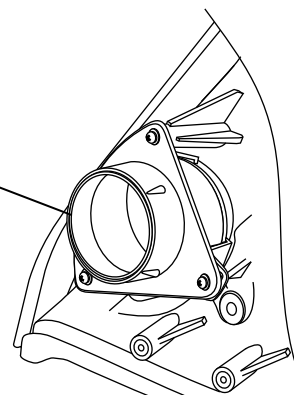

Figure 7



Assembled
View of
A/C Duct
Hose Adapter

Figure 8





www.vintageair.com

Passenger Side Dash Modification

1. Align the template (provided on Page 29) on the back side of the passenger side dash as shown in Figure 9, below.
2. Using a pencil or scribe, mark along the edge of the template as shown.
3. Remove the template and cut along the dotted line. Remove the plastic portion of the dash. **NOTE: Do not cut through the foam dash pad on the back side of the plastic (See Figure 9a, below).**

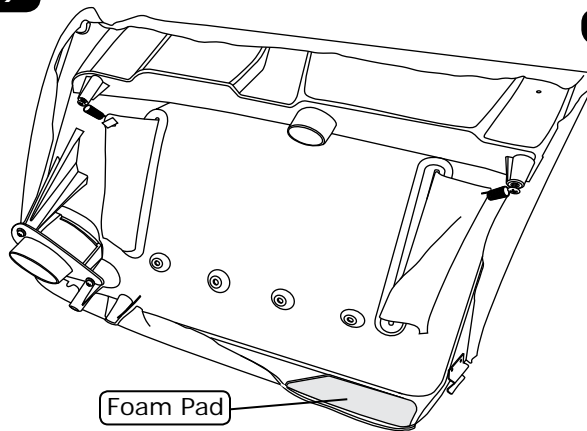
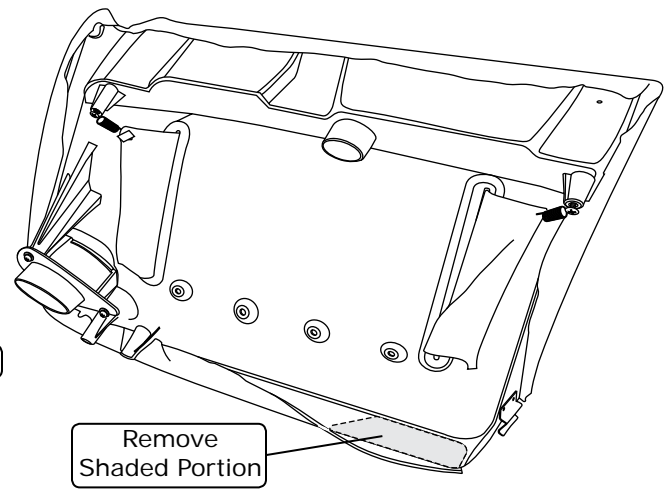
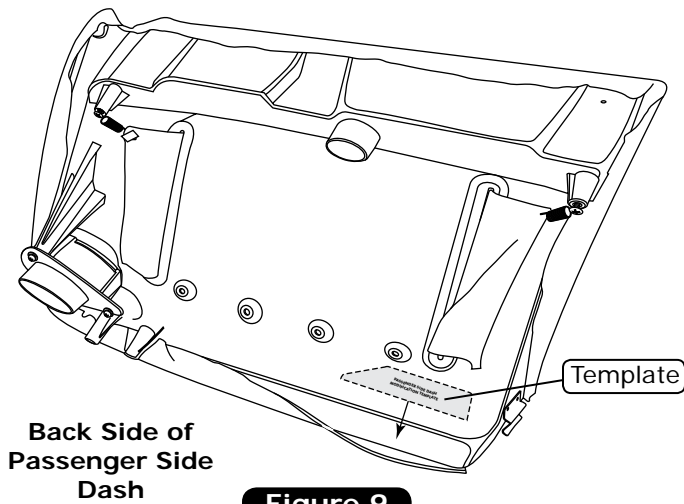



www.vintageair.com

Center Louver Assembly

1. Remove the center louver assembly from the center console.
2. On the rear of the center louver assembly, remove (3) OEM screws attaching the center louver vent door to the center louver frame (retain) (See Photo 4, below). Discard the center louver vent door and housing.
3. Making sure the OEM vents are in their original location, install the center louver adapter to the previously removed OEM vent door location as shown in Photos 5 and 6, below.
4. Install the center louver bracket to the center louver adapter by inserting the vent divider blade through the open slot in the center louver adapter as shown in Photo 7, below.
5. Install and tighten the (3) OEM screws as shown in Photos 8 and 9, below.

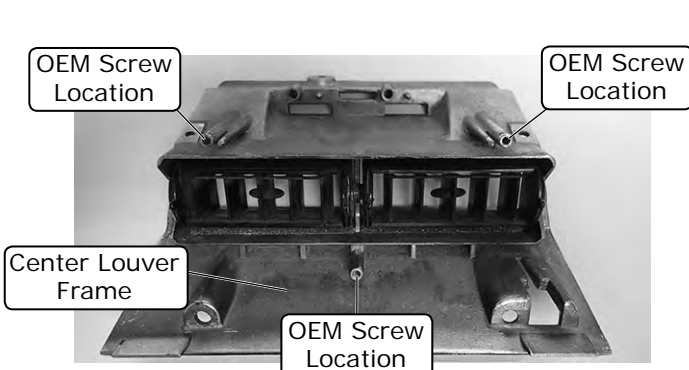

Photo 4

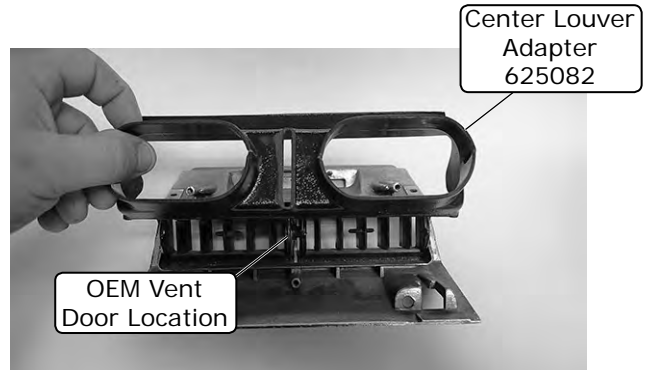

Photo 5



Photo 6

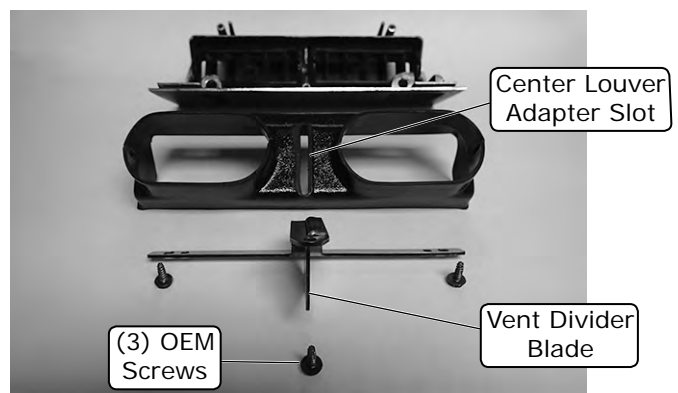

Photo 7

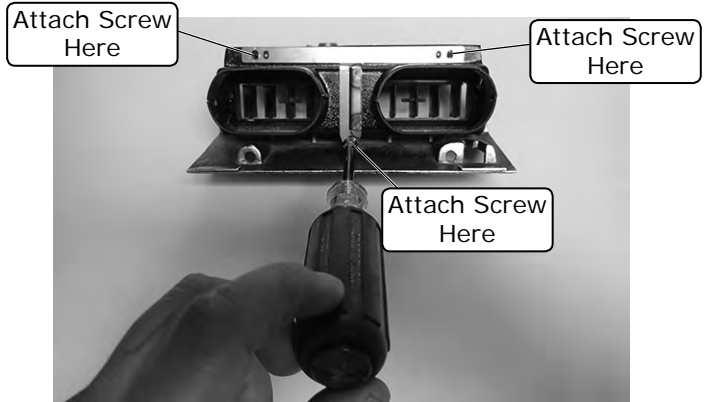

Photo 8

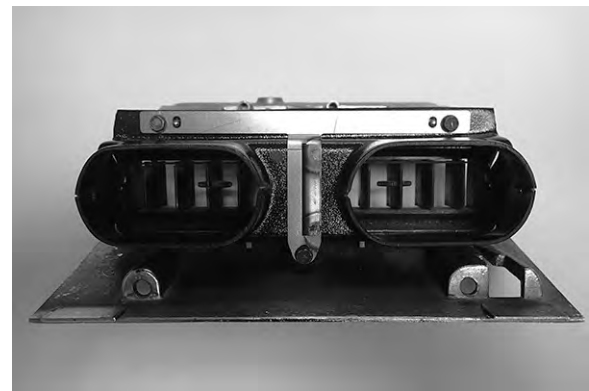

Photo 9

Firewall Modification

1. Cut out the templates provided on Page 30. Working in the passenger compartment, place the templates on the firewall as shown in Figure 10, below.
2. Once templates are aligned correctly and taped into place, mark the mounting hole locations on the firewall. Once the holes are marked in the correct location, drill (2) 3/8" holes in the firewall for the firewall cover (See Figure 10, below).

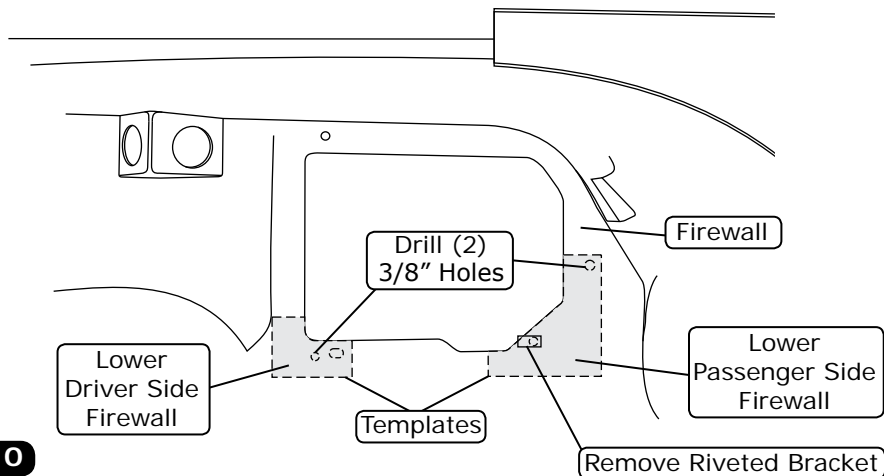

Figure 10

Evaporator Bracket Mounting Holes

1. Cut out the template provided on Page 29. Place the template under the dash on the inner cowl as shown in Figure 11, below.
2. Once the template is aligned correctly against the dash brace, tape the template into place. Mark the mounting hole locations on the inner cowl. Once the holes are marked in the correct location, drill (2) 3/16" holes in the inner cowl for the front evaporator mounting bracket (See Figure 11, below). **NOTE: Some models may have an OEM hole in the inner cowl as shown in Figure 11, below.**

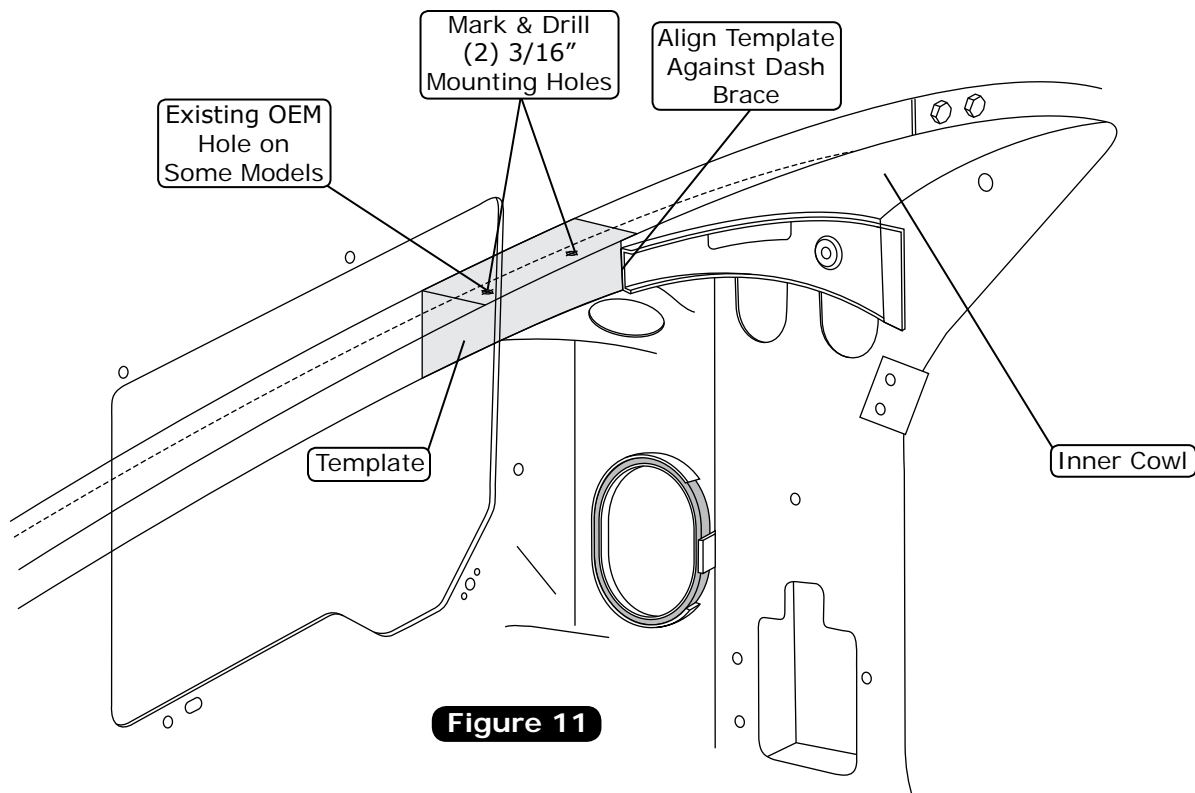

Figure 11



www.vintageair.com

Firewall Modification (Cont.)

1. Working in the engine compartment, place the supplied firewall cover against the opening in the firewall. Align the firewall cover's bolt holes with the (2) previously drilled lower holes and (1) upper OEM hole in the firewall (See Figure 12, below).
2. Using a paint pen or marker, and the firewall cover as a template, mark the firewall along the inside edge of the large hole in the firewall cover to indicate the portion of the firewall that will need to be removed to allow clearance for the A/C and heater lines (See Figure 12, below).
3. When the firewall has been marked as shown in Figure 12, below, remove the marked area from the firewall (See Figure 12a, below).

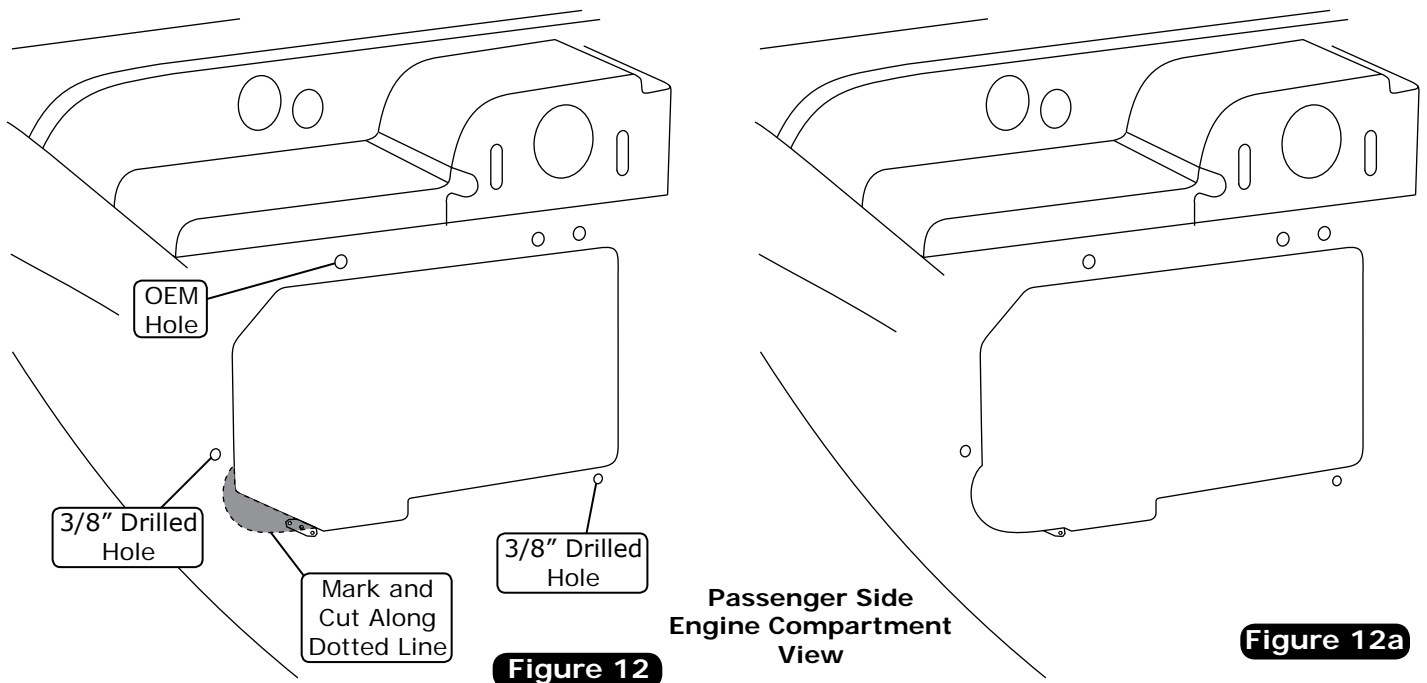

Figure 12

Figure 12a

Evaporator Installation

NOTE: To ensure a watertight seal between the passenger compartment and the vehicle exterior, for all bolts passing through the firewall, Vintage Air recommends coating the threads with silicone prior to installation.

1. On a workbench, install the evaporator rear bracket, and install the evaporator hardlines with properly lubricated O-rings (See Figure 17, Page 19, and Figure 22, Page 23).
2. Install the front mounting bracket on the evaporator using (2) 1/4-20 x 1/2" hex bolts, and tighten as shown in Figure 13, Page 16.
3. Place polyethylene sheet over the stepper motors (See Figure 14, Page 16).
4. Lift evaporator unit up under the dashboard (See Figure 14, Page 16). Secure loosely to the firewall using a 1/4-20 x 1" bolt and washer (See Figure 14, Page 16). **NOTE: To ensure proper drainage, it is very important that the evaporator is level, both left-right and fore-aft. Check for level on the flat portions of the case around the drain.**
5. Using a #14 x 3/4" sheet metal screw, secure the front evaporator mounting bracket to the inner cowl by aligning the right hole in the front evaporator mounting bracket with the OEM hole in the inner cowl (See Figure 14, Page 16).
6. To secure the left side of the front mounting bracket, with the evaporator mounting bracket in place, drill a 3/16" hole in the inner cowl using the left mounting bracket hole as a guide. Secure the bracket to the inner cowl using a #14 x 3/4" sheet metal screw (See Figure 14, Page 16).
7. Verify that the evaporator unit is level and square to the dash; then tighten all mounting bolts. **NOTE: Tighten the bolt on the firewall first. Then tighten the front mounting bracket screws.**



Evaporator Installation (Cont.)

Figure 13

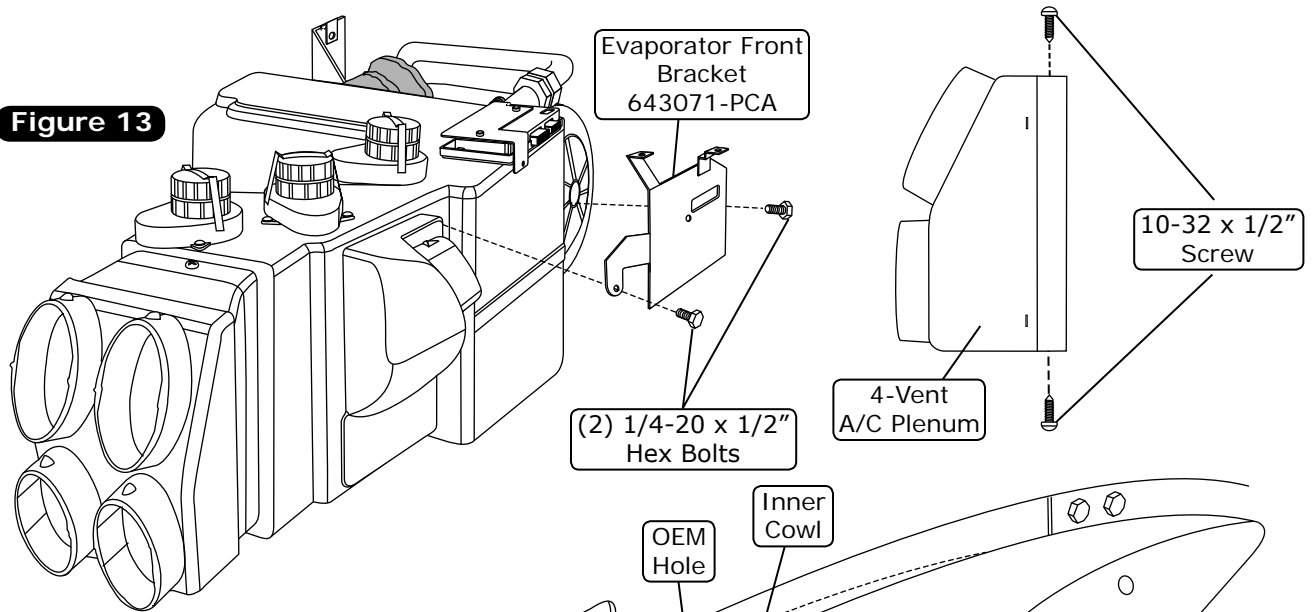

1/4-20 x 1" Bolt & Washer (Install Bolt & Washer From Engine Compartment Side)

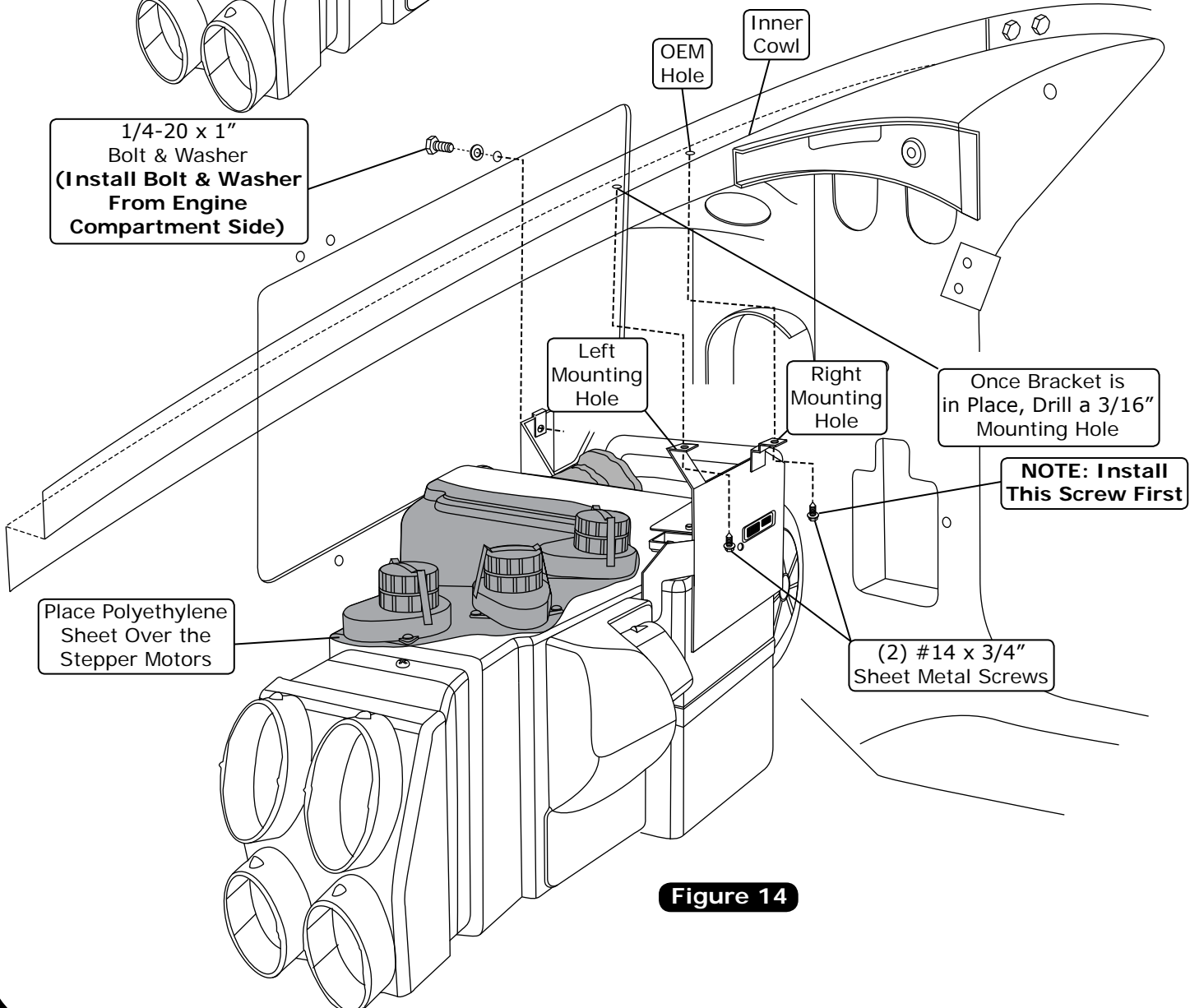

Figure 14



www.vintageair.com

Drain Hose Installation

1. In line with the drain, lightly make a mark on the firewall. Measure 1" down and drill a 5/8" hole through the firewall (See Figure 15, below).
2. Install the drain hose to the bottom of the evaporator unit, and route through the firewall (See Figure 15, below).

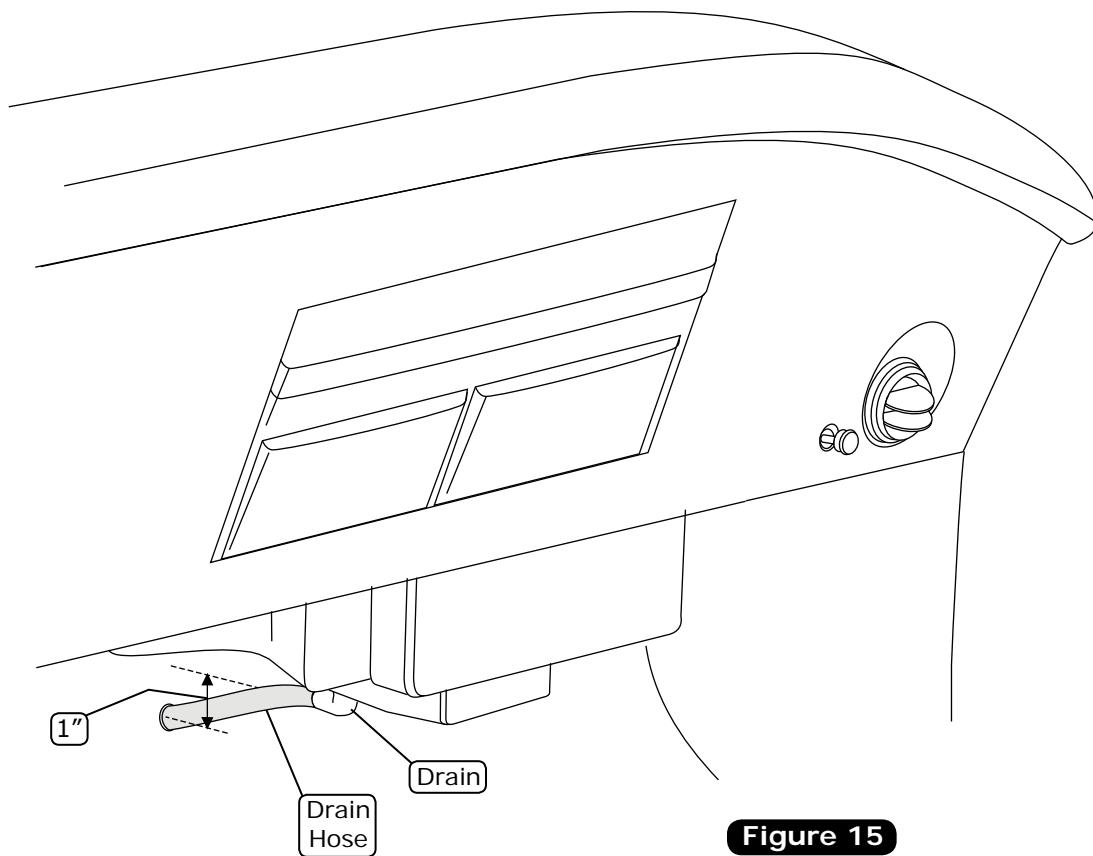



www.vintageair.com

Firewall Cover

1. Apply a 1/4" bead of silicone around the back side of the firewall cover as shown in Figure 16, below.
2. Pass the lines through the firewall cover, and secure with (2) 7/16" panel retainers (See Figure 16, below).
3. Once the firewall cover is in place, locate the hole on the left side of the firewall cover. Drill a 3/8" hole through the firewall. Install a 7/16" panel retainer to secure the left side of the firewall cover to the firewall (See Figure 16, below).
4. Install (2) grommets in the firewall cover cap as shown in Figure 16, below.
5. Apply a 1/4" bead of silicone around the back side of the firewall cover cap as shown in Figure 16, below. Using (2) #8 x 1/2" pan head screws, install the firewall cover cap as shown.

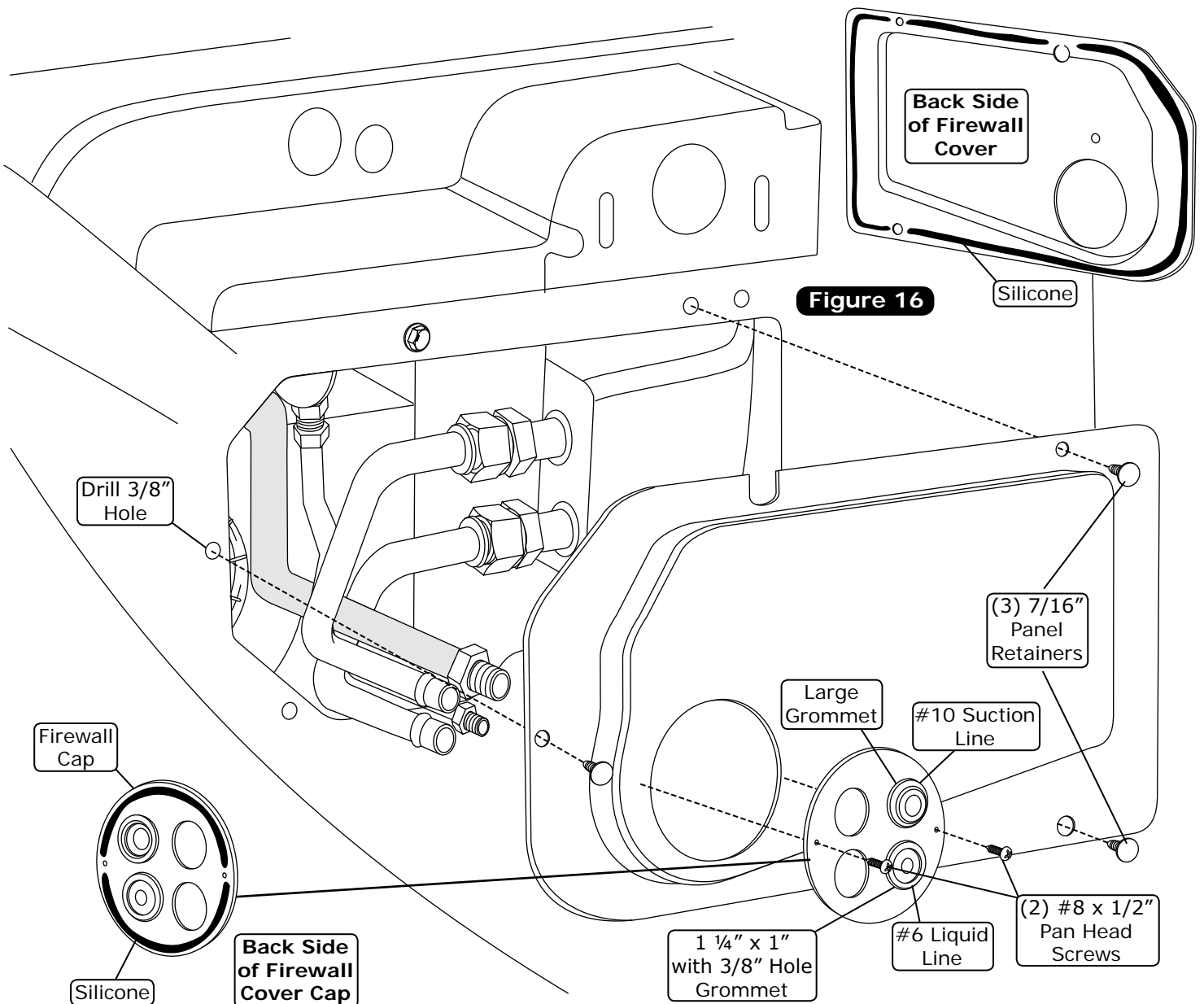



www.vintageair.com

A/C Hose Installation

Standard Hose Kit:

1. Locate the #8 compressor A/C hose. Lubricate (2) #8 O-rings (See Figure 17, below) and connect the 135° female fitting to the #8 discharge port on the compressor. Then route the 45° female fitting to the #8 condenser hardline coming through the core support (See Figure 18, Page 20). Tighten each fitting connection as shown in Figure 17, below.
2. Locate the #10 compressor A/C hose. Lubricate (2) #10 O-rings (See Figure 17, below) and connect the 45° female fitting with 134a service port to the #10 suction port on the compressor. Then route the straight fitting to the #10 evaporator hardline coming through the firewall (See Figure 18, Page 20). Tighten each fitting connection as shown in Figure 17, below. **NOTE: Wrap the #10 fitting connections at the firewall with press tape (See Figure 18, Page 20).**
3. Locate the #6 A/C hose. Lubricate (2) #6 O-rings (See Figure 17, below) and connect the 90° fitting to the #6 hardline coming through the core support from the drier. Attach the straight fitting with 134a service port to the #6 evaporator hardline coming through the firewall (See Figure 18, Page 20). Tighten each fitting connection as shown in Figure 17, below. Use a #6 Adel clamp to secure the #6 A/C hose to the inner fender well as shown in Figure 18, Page 20. Secure the Adel clamp to the inner fender using a 10-32 x 1/2" machine screw and nut.

Modified Hose Kit:

1. Refer to separate instructions included with modified hose kit.

Heater Hose & Heater Control Valve Installation

1. Route a piece of heater hose from the water pump to the heater line coming through the firewall as shown in Figure 19, Page 21. Secure using hose clamps.
2. Route a piece of heater hose from the intake to the heater line coming through the firewall as shown in Figure 19, Page 21. **NOTE: Install heater control valve in line with the intake manifold (pressure side) heater hose, and secure using hose clamps as shown in Figure 19, Page 21. Also note proper flow direction.**

Lubricating O-rings

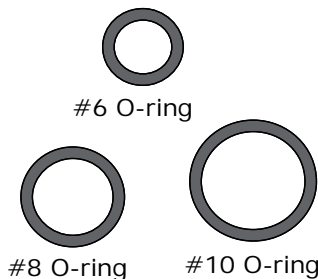

NOTE: Standard torque specifications:
 #6: 11 to 13 ft-lb.
 #8: 15 to 20 ft-lb.
 #10: 21 to 27 ft-lb.

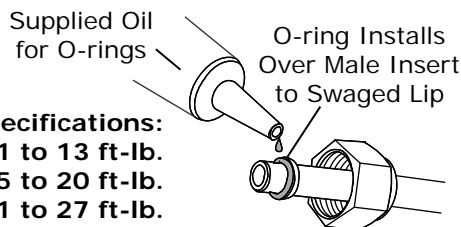
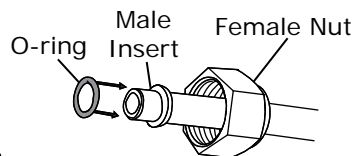

For a proper seal of fittings: Install supplied O-rings as shown and lubricate with supplied oil.

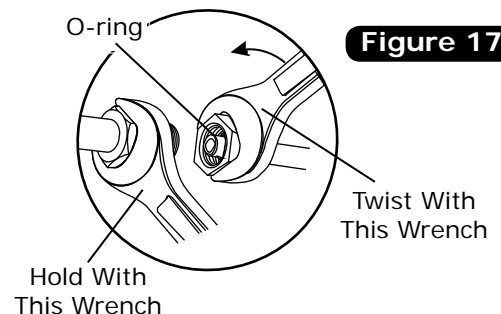

Figure 17



www.vintageair.com

Hose Routing

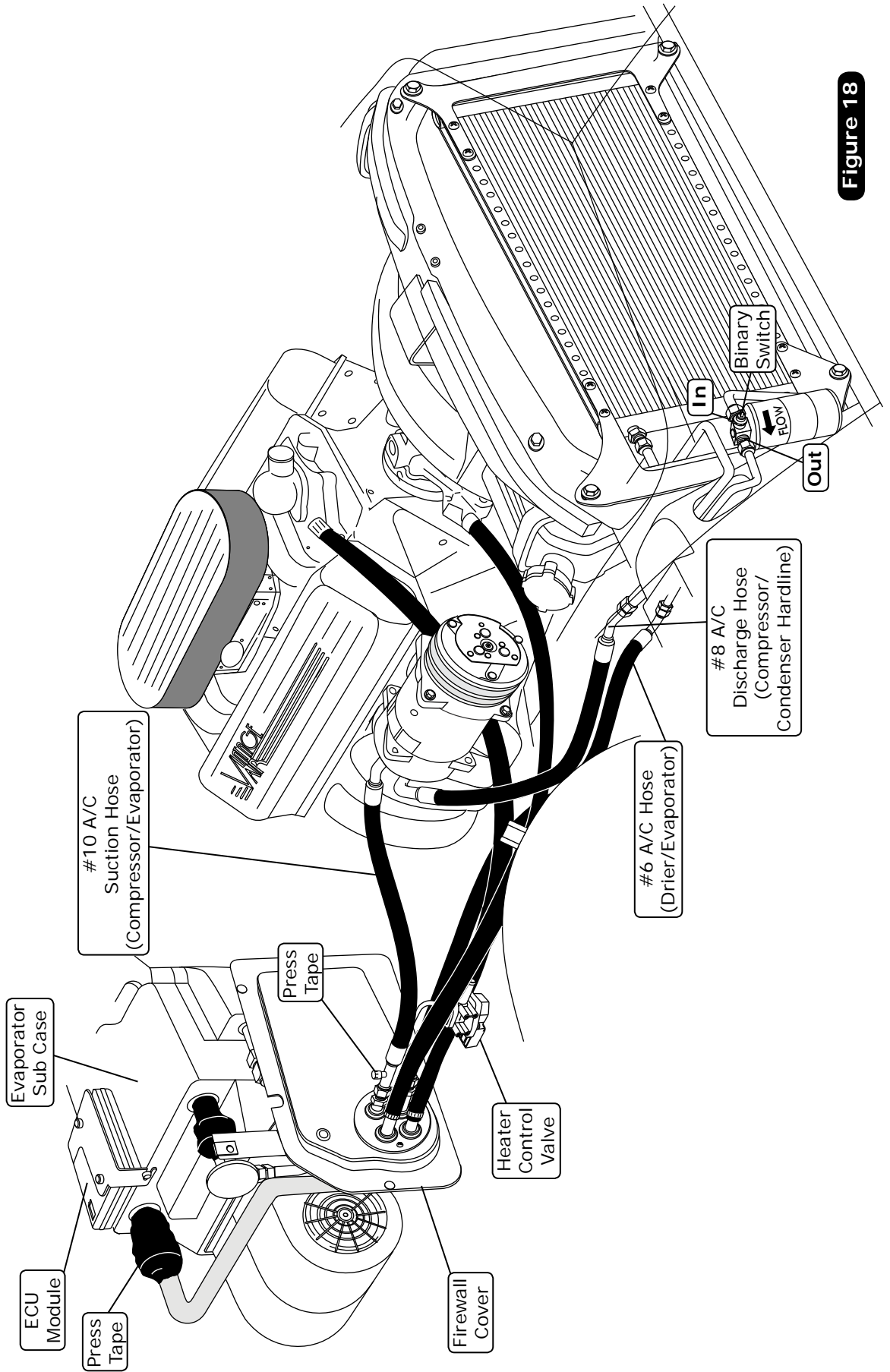

Figure 18



www.vintageair.com

Final Steps

1. Using the supplied tie wraps and a #10 x 3/4" sheet metal screw, install the driver side louver adapter assembly as shown in Figure 20, below. **NOTE: Use the tie wraps to raise and secure the louver adapter assembly.**
2. Install the duct hoses as shown in Figure 21, Page 22.
3. Reinstall the center dash assembly.
4. Reinstall the control panel assembly. Refer to control panel instructions. **NOTE: Controls must be calibrated for proper operation. Refer to control panel instructions.**
5. Plug the control panel harness into the ECU module on the sub case as shown in Figure 21, Page 22.
6. Plug the wiring harnesses into the ECU module on the sub case. Wire according to wiring diagrams on Pages 24 & 25.
7. Reinstall all previously removed items.
8. Fill radiator with at least a 50/50 mixture of approved antifreeze and distilled water. It is the owner's responsibility to keep the freeze protection at the proper level for the climate in which the vehicle is operated. Failure to follow antifreeze recommendations will cause heater core to corrode prematurely and possibly burst in A/C mode and/or freezing weather, voiding your warranty.
9. Double check all fittings, brackets and belts for tightness.
10. Vintage Air recommends that all A/C systems be serviced by a licensed automotive A/C technician.
11. Evacuate the system for a minimum of 45 minutes prior to charging, and perform a leak check prior to servicing.
12. Charge the system to the capacities stated on Page 4 of this instruction manual.
13. See Operation of Controls procedures on Page 26.

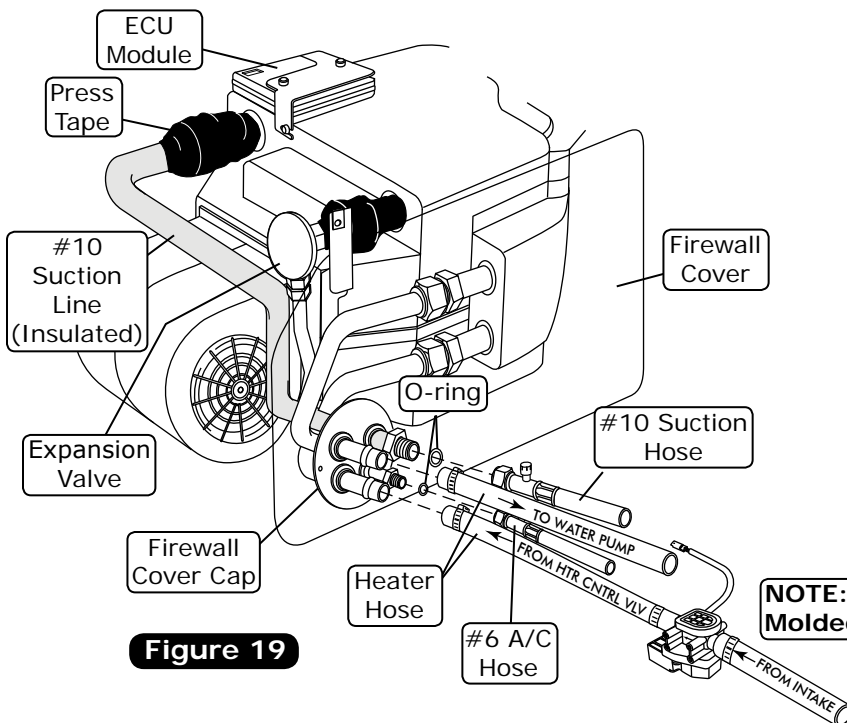

Figure 19

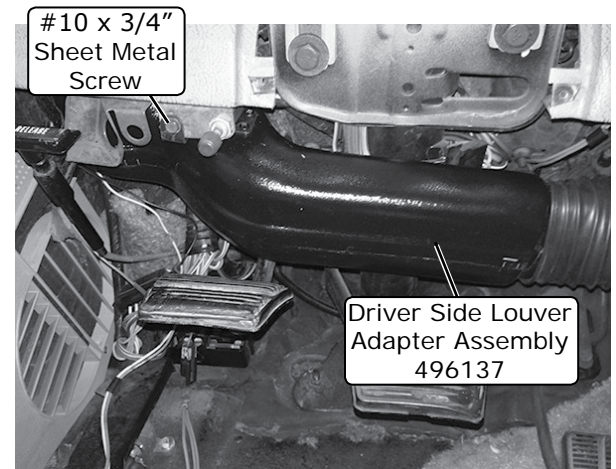

Figure 20

NOTE: Flow Direction Follows Molded Arrow on Valve.



www.vintageair.com

Control Panel & Duct Hose Routing

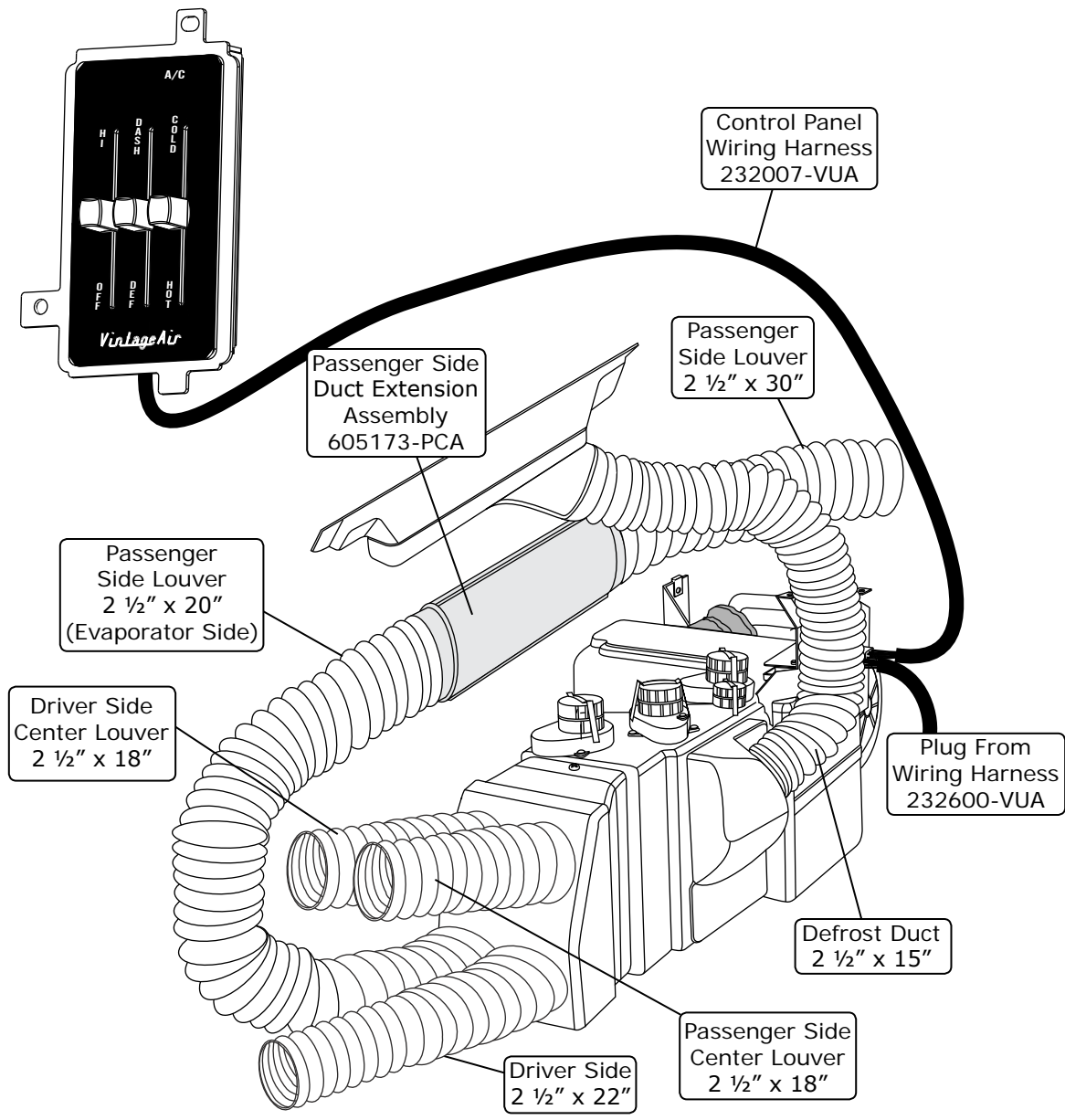
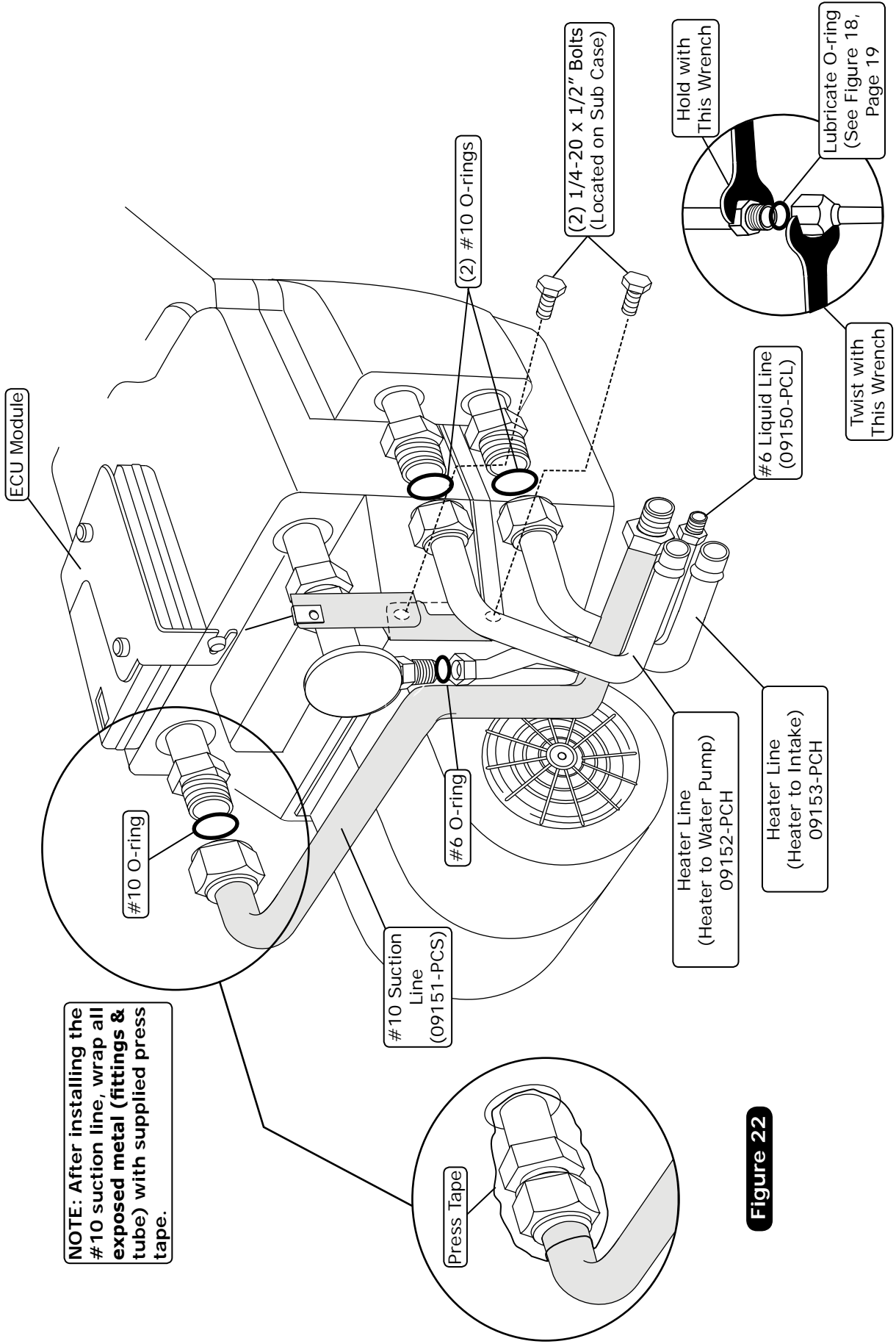

Figure 21



www.vintageair.com

Evaporator Hardline Installation



NOTE: After installing the #10 suction line, wrap all exposed metal (fittings & tube) with supplied press tape.

Figure 22



www.vintageair.com

Wiring Diagram

232007-VUR

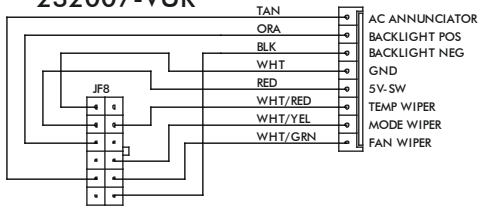

VIEWED FROM WIRE SIDE

232002-VUA

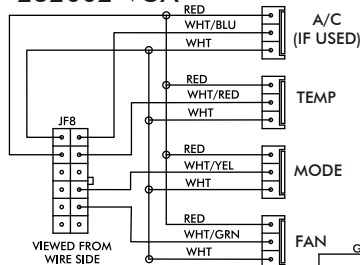

VIEWED FROM WIRE SIDE

PROGRAM

N/A

* DASH LAMP (IF USED)

*** WIDE OPEN THROTTLE SWITCH (OPTIONAL)

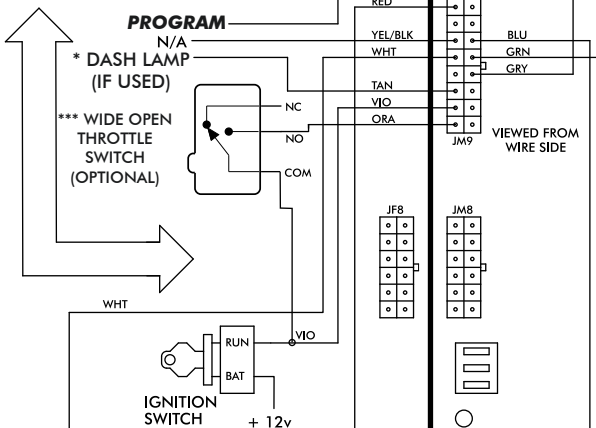

GEN IV ECU

GEN IV WIRING DIAGRAM
REV E, 10/6/2017

PRE-WIRED

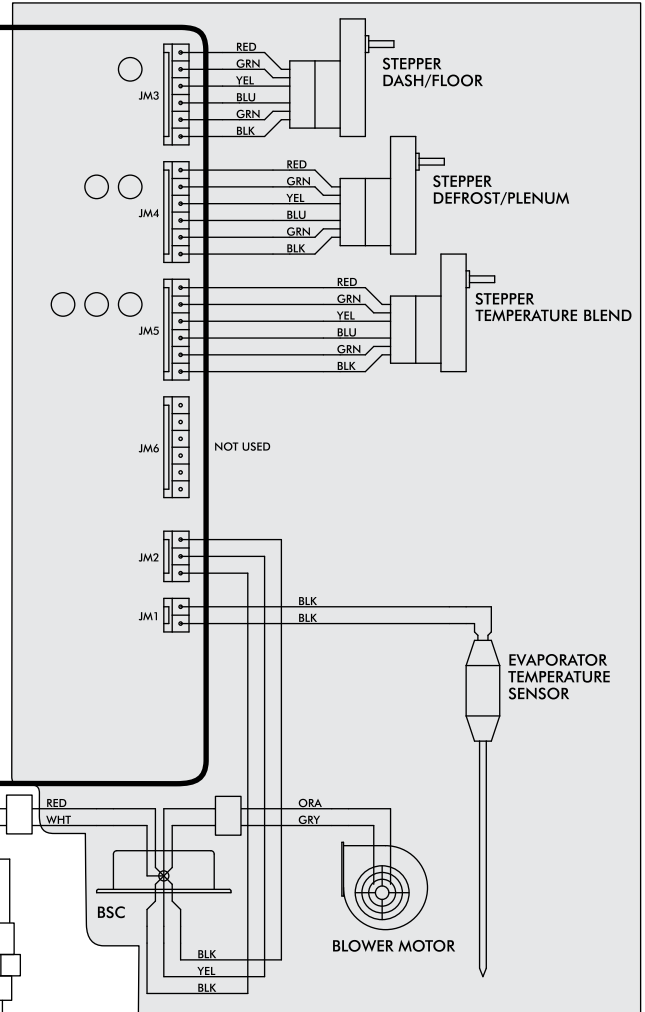

NOTE: = CHASSIS GROUND

- * Dash lamp is used only with type 232007-VUR harness.
- ** Warning: Always mount circuit breaker as close to the battery as possible. (NOTE: Wire between battery and circuit breaker is unprotected and should be carefully routed to avoid a short circuit).
- *** Wide open throttle switch contacts close only at full throttle, which disables A/C compressor.



www.vintageair.com

Gen IV Wiring Connection Instruction

WIRING HARNESS

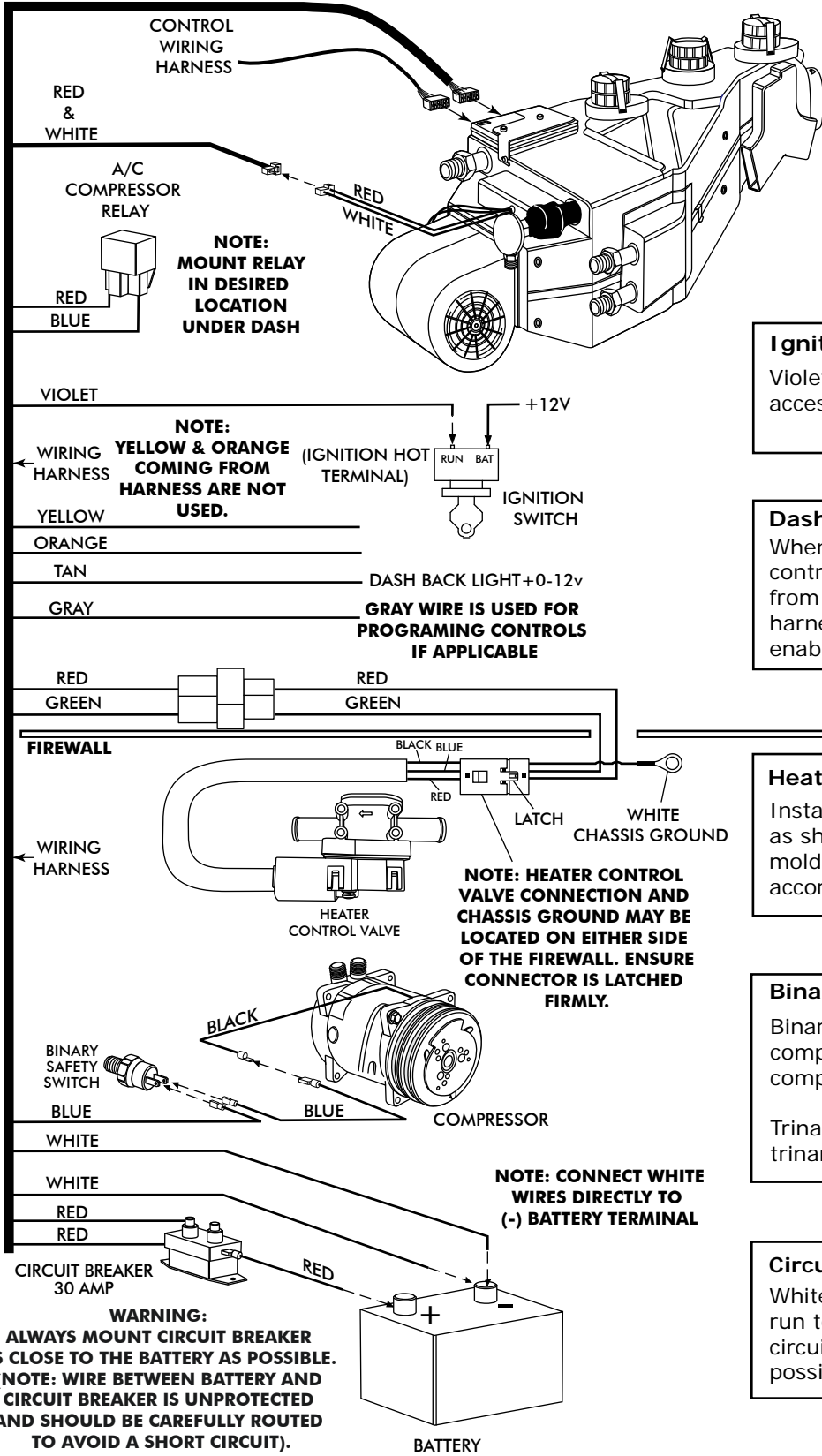

Ignition Switch:
Violet 12V ignition switch source (key on accessory) position must be switched.

Dash Light:
When using a Vintage Air supplied control panel, connect the tan wire from the Gen IV evaporator wiring harness to the factory dash lights to enable panel backlighting.

Heater Control Valve:
Install with servo motor facing down, as shown. Note flow direction arrow molded into valve body and install accordingly.

Binary/Trinary & Compressor:
Binary: Connect as shown (typical compressor wiring). Be sure compressor body is grounded.
Trinary Switch: Connect according to trinary switch wiring diagram.

Circuit Breaker/Battery:
White **must** run to (-) battery. Red may run to (+) battery or starter. Mount circuit breaker as close to battery as possible.

WARNING:
ALWAYS MOUNT CIRCUIT BREAKER AS CLOSE TO THE BATTERY AS POSSIBLE. (NOTE: WIRE BETWEEN BATTERY AND CIRCUIT BREAKER IS UNPROTECTED AND SHOULD BE CAREFULLY ROUTED TO AVOID A SHORT CIRCUIT).



www.vintageair.com

Operation of Controls

On Gen IV systems with three lever/knob controls, the temperature control toggles between heat and A/C operations. To activate A/C, move the temperature lever/knob all the way to cold and then back it off to the desired vent temperature. For heat operation, move the temperature lever/knob all the way to hot and then adjust to the desired vent temperature. The blower will momentarily change speed, each time you toggle between operations, to indicate the change. **NOTE: For proper control panel function, refer to the control panel instructions for calibration procedure.**

Blower Speed

This lever/knob controls blower speed, from OFF to HI.

Mode Control

This lever/knob controls the mode positions, from DEFROST to FLOOR to DASH, with a blend in between.

Temperature Control

This lever/knob controls the temperature, from HOT to COLD.

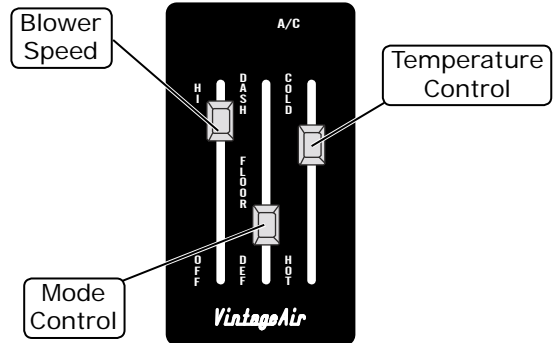

A/C Operation

Blower Speed

Adjust to desired speed.

Mode Control

Adjust to desired mode position (DASH position recommended).

Temperature Control

For A/C operation, adjust to coldest position to engage compressor (Adjust between HOT and COLD to reach desired temperature).

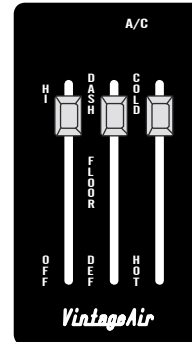

Heat Operation

Blower Speed

Adjust to desired speed.

Mode Control

Adjust to desired mode position (FLOOR position recommended).

Temperature Control

For maximum heating, adjust to hottest position (Adjust between HOT and COLD to reach desired temperature).

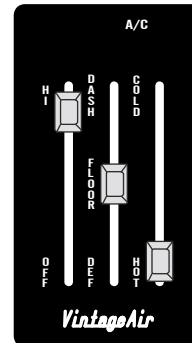

Defrost/De-fog Operation

Blower Speed

Adjust to desired speed.

Temperature Control

Adjust to desired temperature.

Mode Control

Adjust to DEFROST position for maximum defrost, or between FLOOR and DEFROST positions for a bi-level blend (Compressor is automatically engaged).

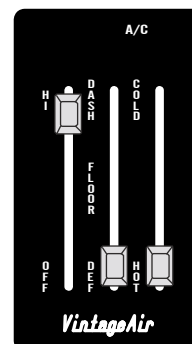



www.vintageair.com

Troubleshooting Guide

Symptom	Condition	Checks	Actions	Notes
1a. Blower stays on high speed when ignition is on.	No other functions work.	Check for damaged pins or wires in control head plug.	Verify that all pins are inserted into plug. Ensure that no pins are bent or damaged in ECU.	Loss of ground on this wire renders control head inoperable.
		Check for damaged ground wire (white) in control head harness.	Verify continuity to chassis ground with white control head wire at various points.	
	All other functions work.	Check for damaged blower switch or potentiometer and associated wiring.		See blower switch check procedure.
1b. Blower stays on high speed when ignition is on or off.		Unplug 3-wire BSC control connector from ECU. If blower shuts off, ECU is either improperly wired or damaged.	Be sure the small, 20 GA white ground wire is connected to the battery ground post. If it is, replace the ECU.	No other part replacements should be necessary.
		Unplug 3-wire BSC control connector from ECU. If blower stays running, BSC is either improperly wired or damaged.	Check to ensure that no BSC wiring is damaged or shorted to vehicle ground. The BSC operates the blower by ground side pulse width modulation switching. The positive wire to the blower will always be hot. If the "ground" side of the blower is shorted to chassis ground, the blower will run on HI.	
			Replace BSC (This will require removal of evaporator from vehicle).	
2. Compressor will not turn on (All other functions work).		System is not charged.	Charge system or bypass pressure switch.	Danger: Never bypass safety switch with engine running. Serious injury can result.
		System is charged.	Check for faulty A/C potentiometer or associated wiring (not applicable to 3-pot controls).	To check for proper pot function, check voltage at white/blue wire. Voltage should be between 0V and 5V, and will vary with pot lever position.
			Check for disconnected or faulty thermistor.	Disconnected or faulty thermistor will cause compressor to be disabled.
			Repair or replace pot/control wiring.	Red wire at A/C pot should have approximately 5V with ignition on. White wire will have continuity to chassis ground. White/Blue wire should vary between 0V and 5V when lever is moved up or down.
			Check for faulty A/C relay.	Replace relay.
3. Compressor will not turn off (All other functions work).				



www.vintageair.com

Troubleshooting Guide (Cont.)

Symptom	Condition	Checks	Actions	Notes	
4.	Works when engine is not running; shuts off when engine is started (typically early Gen IV, but possible on all versions). System will not turn on, or runs intermittently.	Will not turn on under any conditions.	Noise interference from either ignition or alternator.	Install capacitors on ignition coil and alternator. Ensure good ground at all points. Relocate coil and associated wiring away from ECU and ECU wiring. Check for burned or loose plug wires.	Ignition noise (radiated or conducted) will cause the system to shut down due to high voltage spikes. If this is suspected, check with a quality oscilloscope. Spikes greater than 16V will shut down the ECU. Install a radio capacitor at the positive post of the ignition coil (see radio capacitor installation bulletin). A faulty alternator or worn out battery can also result in this condition.
			Verify connections on power lead, ignition lead, and both white ground wires.	Check for positive power at heater valve green wire and blower red wire. Check for ground on control head white wire.	
			Verify battery voltage is greater than 10 volts and less than 16.	Verify proper meter function by checking the condition of a known good battery.	
5.	Loss of mode door function.	No mode change at all.	Check for damaged mode switch or potentiometer and associated wiring.	Typically caused by evaporator housing installed in a bind in the vehicle. Be sure all mounting locations line up and don't have to be forced into position.	
		Partial function of mode doors.	Check for obstructed or binding mode doors.		
			Check for damaged stepper motor or wiring.		
6.	Blower turns on and off rapidly.	Battery voltage is at least 12V.	Check for at least 12V at circuit breaker.	System shuts off blower at 10V. Poor connections or weak battery can cause shutdown at up to 11V.	
		Battery voltage is less than 12V.	Check for faulty battery or alternator.		
7.	Erratic functions of blower, mode, temp, etc.	Check for damaged switch or pot and associated wiring.	Repair or replace.		
8.	When ignition is turned on, blower momentarily comes on, then shuts off. This occurs with the blower switch in the OFF position.	This is an indicator that the system has been reset. Be sure the red power wire is on the battery post, and not on a switched source. Also, if the system is pulled below 7V for even a split second, the system will reset.	Run red power wire directly to battery.		



Passenger Compartment Modification Templates

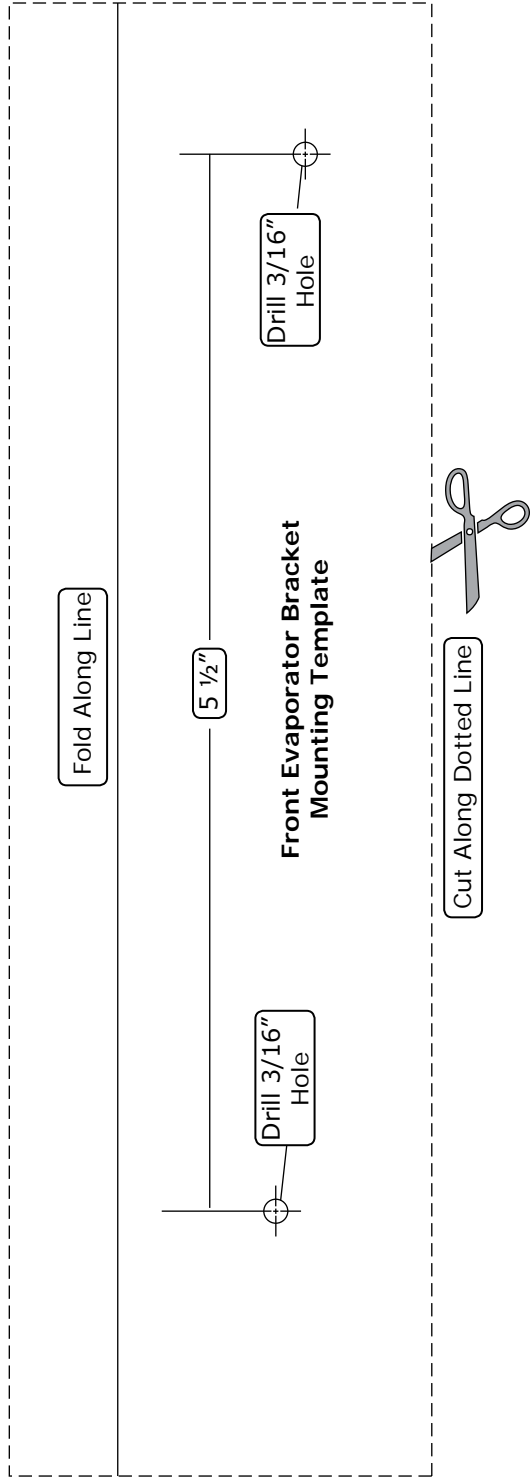
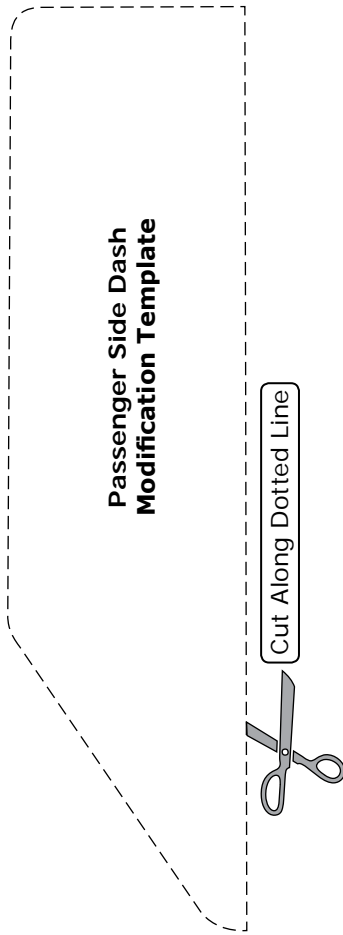



Firewall Modification Templates

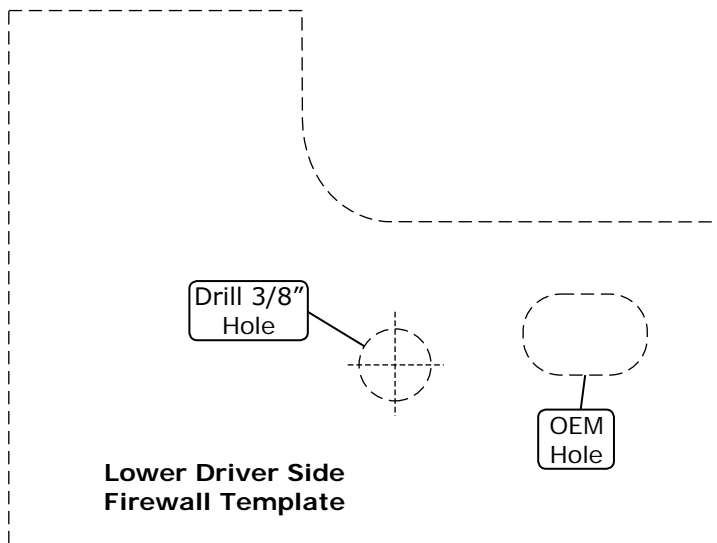
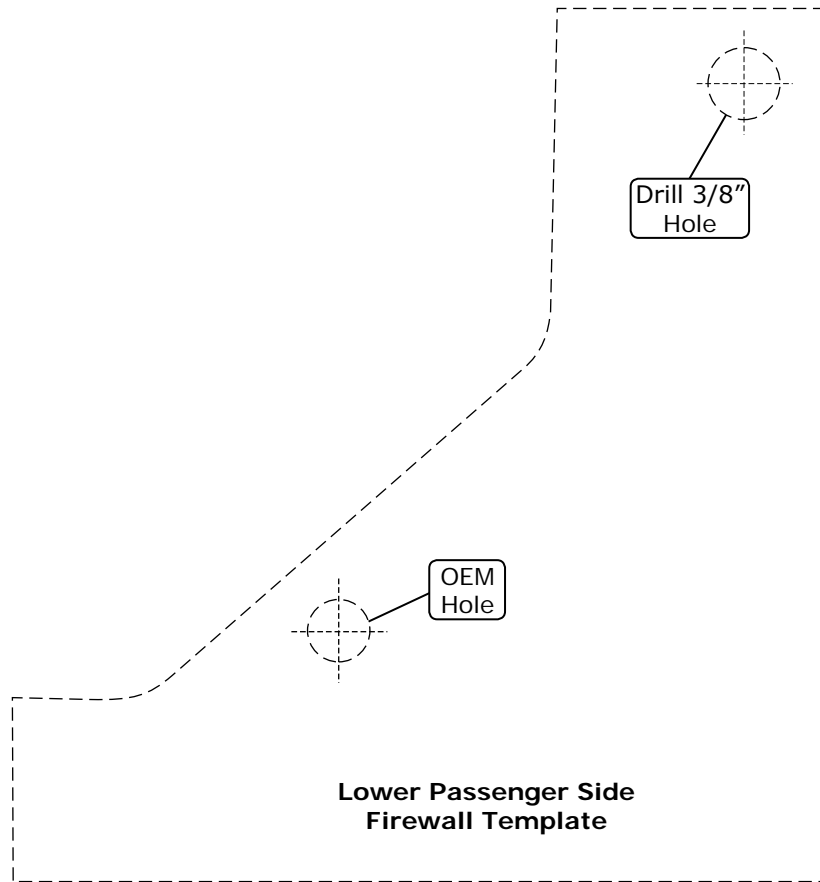



Packing List: Evaporator Kit (564168)

No.	Qty.	Part No.	Description
1.	1	764172	Gen IV Evaporator Sub Case
2.	1	784170	Accessory Kit

Checked By: _____
 Packed By: _____
 Date: _____

1

Gen IV Evaporator
Sub Case
764172

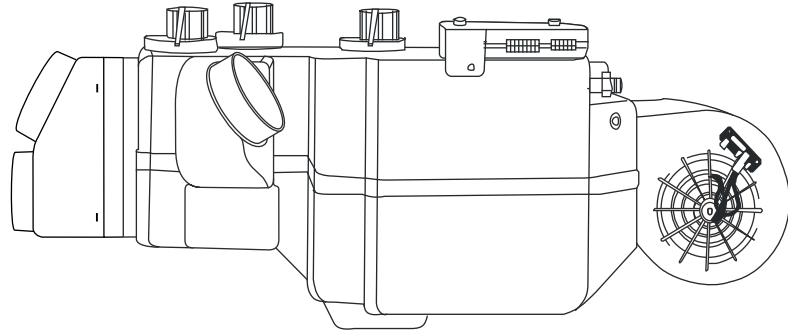

2

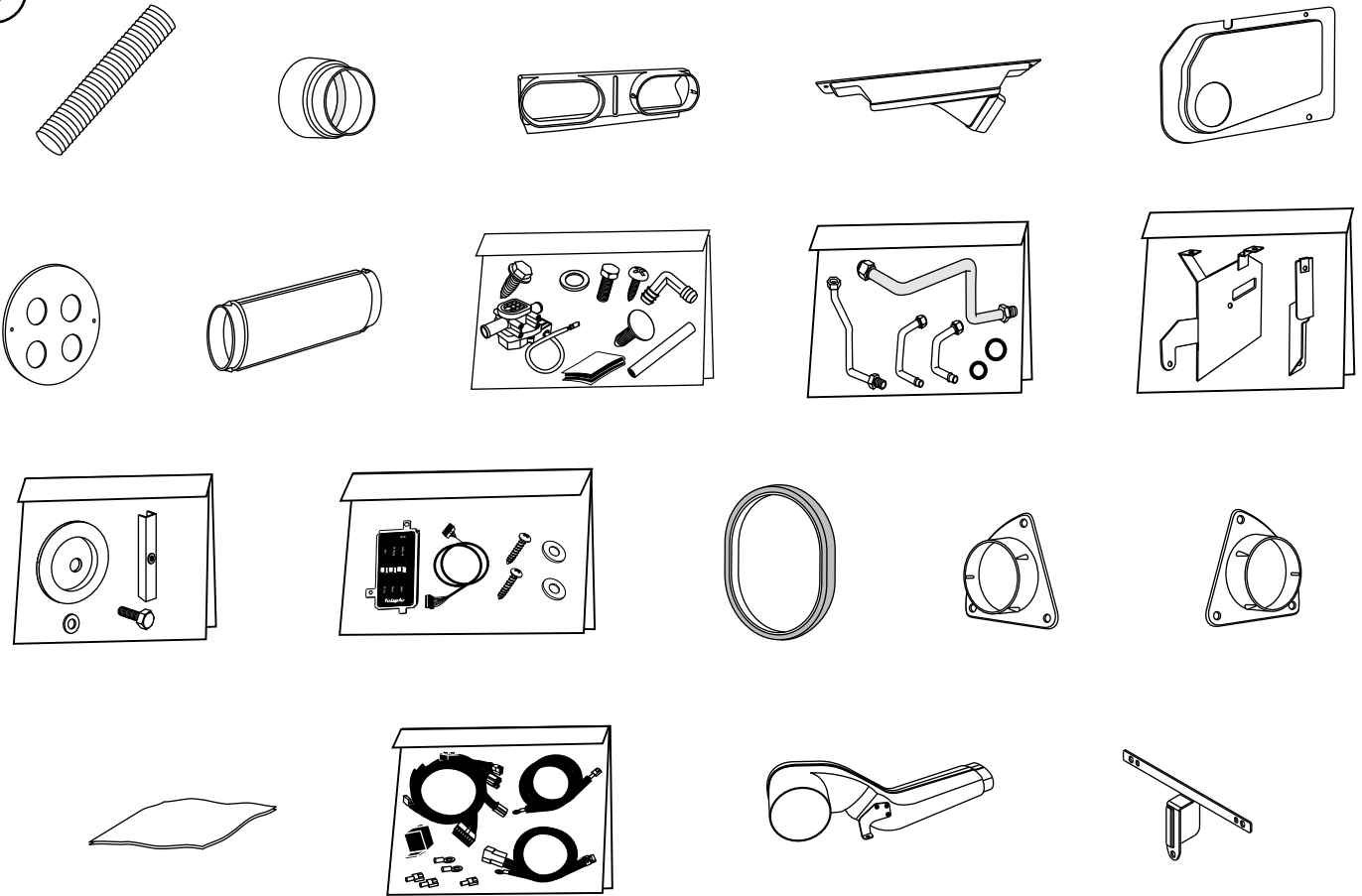

Accessory Kit
784170

**NOTE: Images may not depict actual parts and quantities.
Refer to packing list for actual parts and quantities.**