



an ISO 9001:2015 Registered Company

1978-82 Chevrolet Corvette

with Factory Air
Evaporator Kit
(564176)



18865 Goll St. San Antonio, TX 78266
Phone: 800-862-6658
Sales: sales@vintageair.com
Tech Support: tech@vintageair.com
www.vintageair.com



www.vintageair.com

Table of Contents

Cover.....	1
Table of Contents.....	2
Packing List/Parts Disclaimer.....	3
Information Page.....	4
Wiring Notice.....	5
Engine Compartment Disassembly.....	6
Passenger Compartment Disassembly.....	7
Passenger Compartment Disassembly (Cont.), Fresh Air Cover Installation, Condenser Assembly and Installation, Compressor and Brackets.....	8
Defrost Duct Replacement.....	9
Driver and Passenger Side OEM Louver Modification.....	10
Center Louver Hose Adapter Installation.....	11
Firewall Modification.....	12
Evaporator Preparation, Lubricating O-rings.....	13
Evaporator Installation.....	14
Evaporator A/C Hose Installation.....	15
Firewall Cover.....	16
Firewall Cover (Cont.), Firewall Rubber Boot and Evaporator Firewall Ring Installation.....	17
A/C Hose Installation.....	18
Drain Hose Installation, Heater Hose & Heater Control Valve Installation.....	19
Heater Hose & Heater Control Valve Installation (Cont.).....	20
Wiring.....	21
Wiring (Cont.).....	22
Wiring (Cont.).....	23
Wiring (Final).....	24
Hose Routing.....	25
Final Steps.....	26
Control Panel & Duct Hose Routing.....	27
Wiring Diagram.....	28
Gen IV Wiring Connection Instruction.....	29
Operation of Controls.....	30
Troubleshooting Guide.....	31
Troubleshooting Guide (Cont.).....	32
Packing List.....	33



www.vintageair.com

Packing List: Evaporator Kit (564176)

No.	Qty.	Part No.	Description
1.	1	764172	Gen IV Evaporator Sub Case
2.	1	785176	Accessory Kit

**** Before beginning installation, open all packages and check contents of shipment. Please report any shortages directly to Vintage Air within 15 days. After 15 days, Vintage Air will not be responsible for missing or damaged items.**

1

Gen IV Evaporator
Sub Case
764172

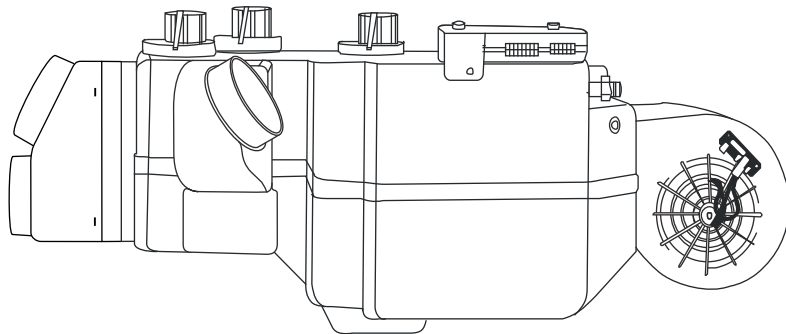

2



Accessory Kit
785176

NOTE: Images may not depict actual parts and quantities. Refer to packing list for actual parts and quantities.



www.vintageair.com

Important Notice—Please Read

For Maximum System Performance, Vintage Air Recommends the Following:

NOTE: Vintage Air systems are designed to operate with R134a refrigerant only. Use of any other refrigerant could damage your A/C system and/or vehicle, and possibly cause a fire, in addition to potentially voiding the warranties of the A/C system and its components.

Refrigerant Capacities:

Vintage Air System: 1.8 lbs. (28.8 oz.) or 816 grams of **R134a**, charged by weight with a quality charging station or scale. **NOTE: Use of the proper type and amount of refrigerant is critical to system operation and performance.**

Other Systems: Consult manufacturer's guidelines.

Lubricant Capacities:

New Vintage Air-Supplied Sanden Compressor: No additional oil needed (Compressor is shipped with proper oil charge).

All Other Compressors: Consult manufacturer (Some compressors are shipped dry and will need oil added).

Safety Switches

Your Vintage Air system is equipped with a binary pressure safety switch. A binary switch disengages the compressor clutch in cases of extreme low pressure conditions (refrigerant loss) or excessively high head pressure (406 PSI) to prevent compressor damage or hose rupture. A trinary switch combines Hi/Lo pressure protection with an electric fan operation signal at 254 PSI, and should be substituted for use with electric fans. Compressor safety switches are extremely important since an A/C system relies on refrigerant to circulate lubricant.

Service Info:

Protect Your Investment: Prior to assembly, it is critical that the compressor, evaporator, A/C hoses and fittings, hardlines, condenser and receiver/drier remained capped. Removing caps prior to assembly will allow moisture, insects and debris into the components, possibly leading to reduced performance and/or premature failure of your A/C system. This is especially important with the receiver/drier.

Additionally, when caps are removed for assembly, **BE CAREFUL!** Some components are shipped under pressure with dry nitrogen.

Evacuate the System for 35-45 Minutes: Ensure that system components (Drier, compressor, evaporator and condenser) are at a temperature of at least 85°F. On a cool day, the components can be heated with a heat gun **or** by running the engine with the heater on before evacuating. Leak check and charge to specifications.

Bolts Passing Through Cowl and/or Firewall:

To ensure a watertight seal between the passenger compartment and the vehicle exterior, for all bolts passing through the cowl and/or firewall, Vintage Air recommends coating the threads with silicone prior to installation.

Heater Hose (not included with this kit):

Heater hose may be purchased from Vintage Air (Part#31800-VUD) or your local parts retailer. Routing and required length will vary based on installer preference.



www.vintageair.com

Important Wiring Notice—Please Read

Some vehicles may have had some or all of their radio interference capacitors removed. There should be a capacitor found at each of the following locations:

- 1. On the positive terminal of the ignition coil.**
- 2. If there is a generator, on the armature terminal of the generator.**
- 3. If there is a generator, on the battery terminal of the voltage regulator.**

Most alternators have a capacitor installed internally to eliminate what is called “whining” as the engine is revved. If whining is heard in the radio, or just to be extra cautious, a radio interference capacitor can be added to the battery terminal of the alternator.

It is also important that the battery lead is in good shape and that the ground leads are not compromised. There should be a heavy ground from the battery to the engine block, and additional grounds to the body and chassis.

If these precautions are not observed, it is possible for voltage spikes to be present on the battery leads. These spikes come from ignition systems and charging systems, and from switching some of the vehicle’s other systems on and off. Modern computer-operated equipment can be sensitive to voltage spikes on the power leads, which can cause unexpected resets, strange behavior and/or permanent damage.

Vintage Air strives to harden our products against these types of electrical noise, but there is a point where a vehicle’s electrical system can be degraded so much that nothing can help.

Radio interference capacitors should be available at most auto and truck parts suppliers. They typically are cylindrical in shape, a little over an inch long and a little over a half inch in diameter, and they have a single lead coming from one end of the cylinder with a terminal on the end of the wire, as well as a mounting clip which is screwed into a good ground on the vehicle. The specific value of the capacitance is not too significant in comparison to ignition capacitors that are matched with the coil to reduce pitting of the points.

- Care must be taken, when installing the compressor lead, not to short it to ground. The compressor lead must not be connected to a condenser fan or to any other auxiliary device. Shorting to ground or connecting to a condenser fan or any other auxiliary device may damage wiring or the compressor relay, and/or cause a malfunction.
- When installing ground leads on Gen IV systems, the blower control ground and ECU ground must be connected directly to the negative battery post.
- For proper system operation, the heater control valve must be connected to the ECU.



www.vintageair.com

Engine Compartment Disassembly

NOTE: Before starting the installation, check the function of the vehicle (horn, lights, etc.) for proper operation, and study the instructions, illustrations, & diagrams.

Perform the Following:

1. Disconnect the battery.
2. Remove the hood to ease installation.
3. Drain the radiator.
4. Evacuate the A/C system (if necessary).
5. Remove the OEM condenser and drier (discard).
6. Remove the OEM A/C lines from the compressor to the evaporator (discard).
7. Remove the OEM compressor and the compressor bracket (discard).
8. Remove the coolant overflow bottle by removing (3) bolts and the overflow hose (retain).
9. Remove the OEM blower assembly and cover (discard).
10. Remove the OEM evaporator and cover (discard).
11. Remove the OEM A/C harness and vacuum harness (discard).
12. Install a 1 5/8" plug into the firewall as shown in Photo 1, below. **NOTE: Apply a small bead of silicone onto the back edge of the plug and install.**



Photo 1

1 5/8" Plug

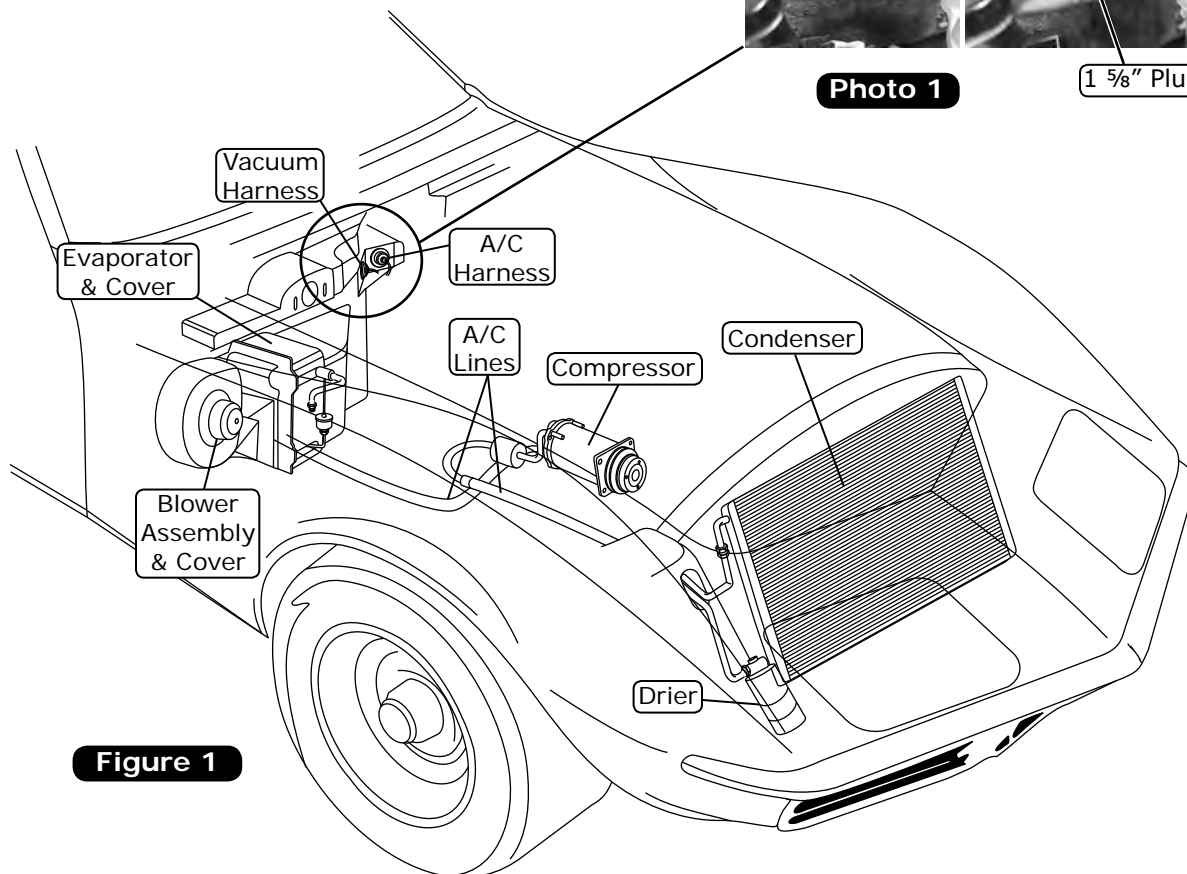

Figure 1



www.vintageair.com

Passenger Compartment Disassembly

Perform the Following:

1. Remove the center console (retain).
2. Remove the glove box (discard), retain mounting screws and light switch.
3. Remove the dash (retain).
4. Remove the OEM radio (retain).
5. Remove the control panel (discard). Refer to the control panel kit to install new control panel.
6. Remove the passenger side, center and driver side A/C plenums as shown in Figure 2, below (discard).
7. Remove the floor heater duct as shown in Figure 2, below (discard).

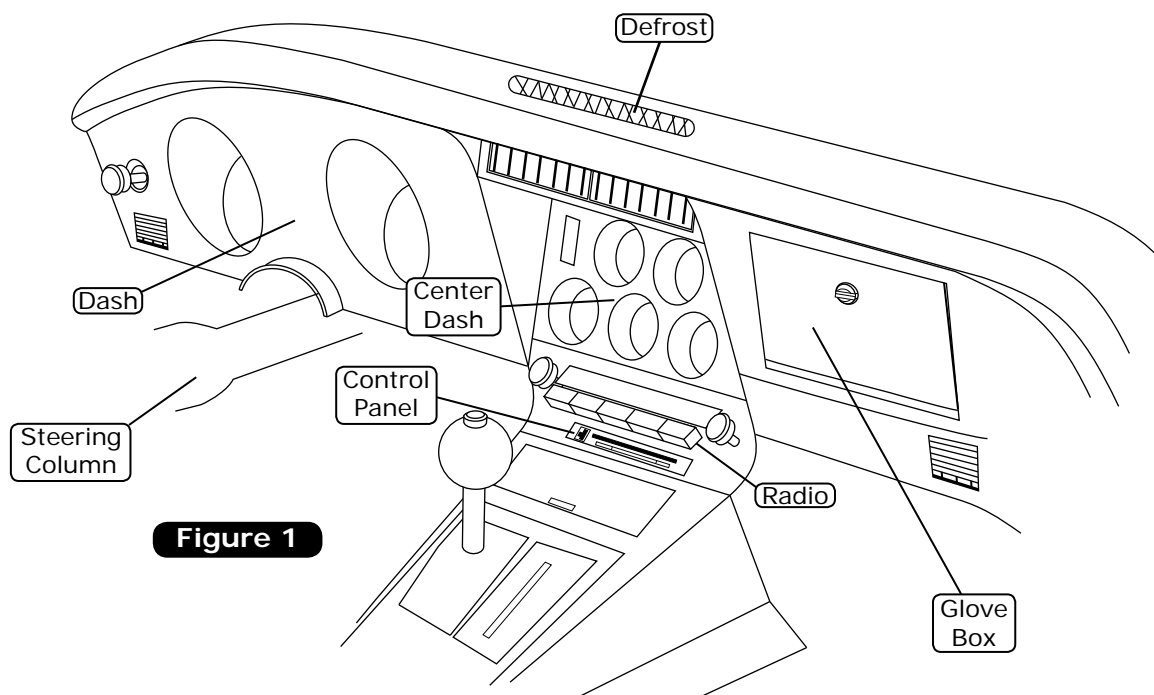

Figure 1

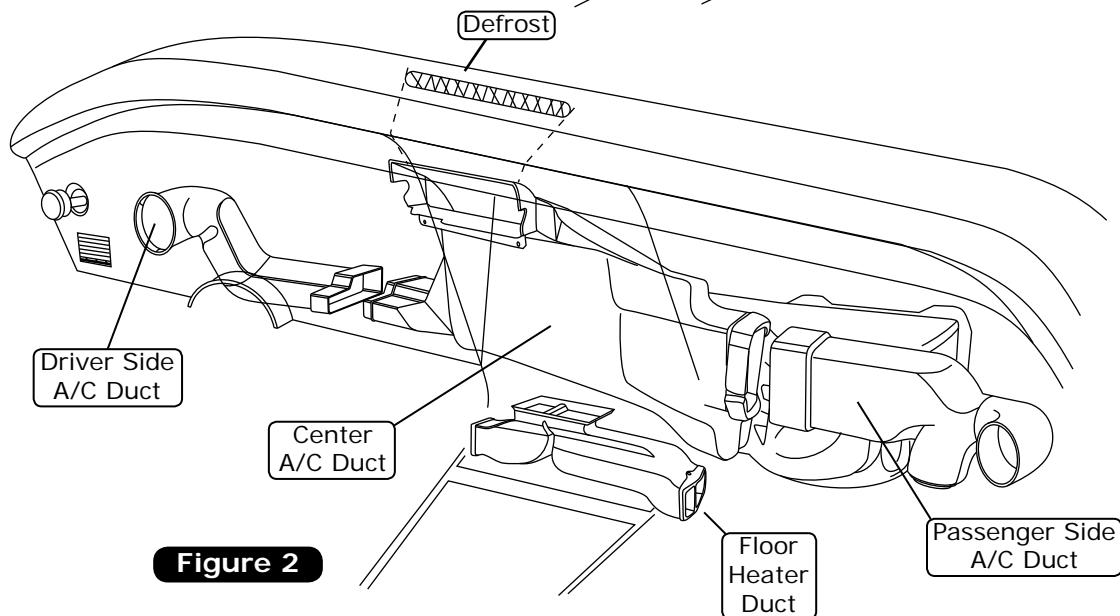

Figure 2



www.vintageair.com

Passenger Compartment Disassembly (Cont.)

8. Remove the OEM defrost duct (discard).
9. Remove the heater housing from under the dash.
10. Remove the kick panel vacuum control assembly (discard) (See Figure 3a, below).
11. Using (2) #8 x 1/2" pan head screws, install the kick panel fresh air cap as shown in Figure 3a, below. Prior to final installation, mark and drill (2) 1/8" holes using the kick panel fresh air cap as a template.

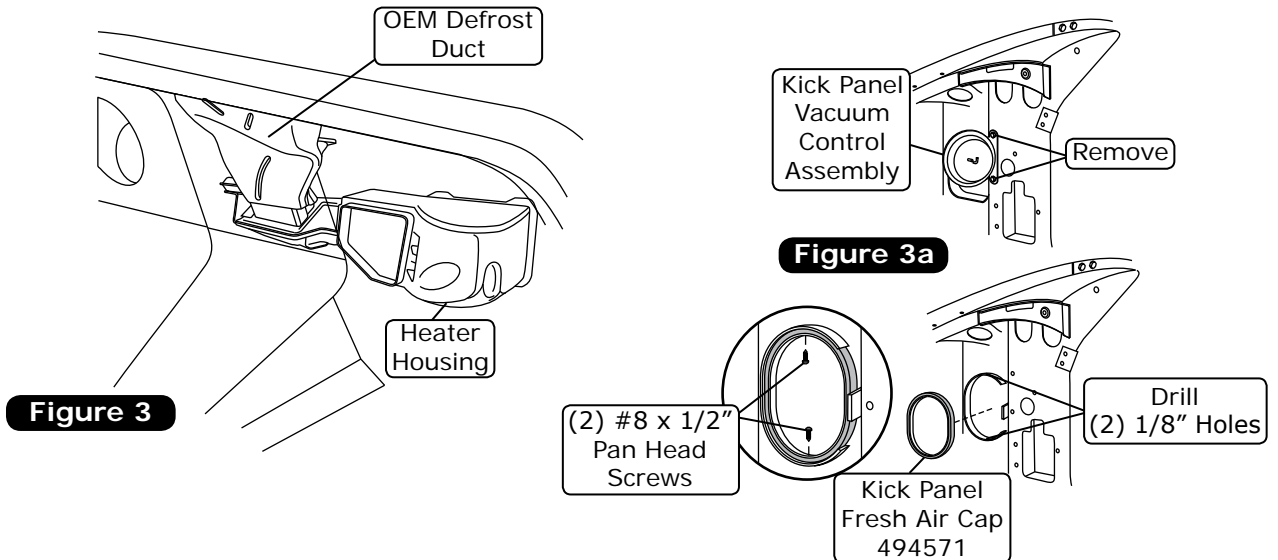

Fresh Air Cover Installation

1. Apply a 1/4" bead of silicone around the mating surface of the fresh air cap as shown in Figure 1, below.
2. Attach the fresh air cap to the firewall using a 1/4-20 x 1" bolt and washer (See Figure 1, below).

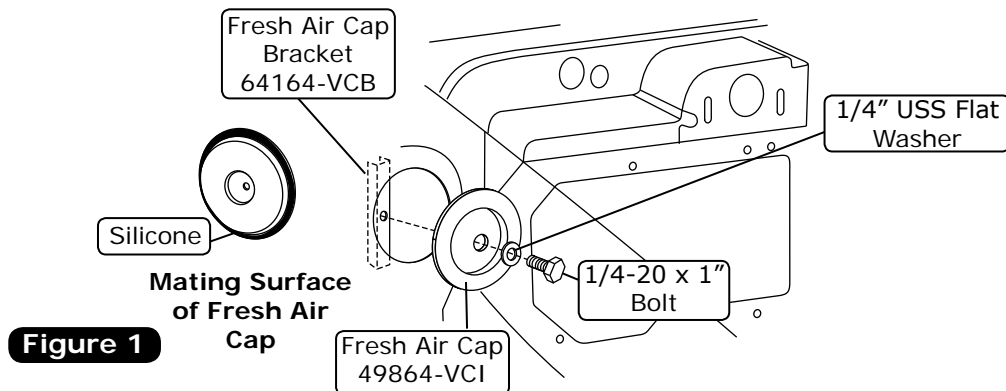

Condenser Assembly and Installation

1. Refer to separate instructions included with the condenser kit to install the condenser.

Compressor and Brackets

1. Refer to separate instructions included with the bracket kit to install the compressor bracket.



www.vintageair.com

Defrost Duct Replacement

1. Remove (2) OEM dash screws and (2) OEM dash clips (retain) (See Photo 1, below).
2. Center the 2 1/2" single defrost duct over the defrost opening on the dash (See Photo 2, below), and place the defrost duct support brackets into position as shown in Photo 3, below. Temporarily install the brackets to the dash using the OEM screws (See Photo 3, below).
3. Mark the bracket mounting holes ((2) on each side), then remove the OEM screws and the defrost duct. Using a 3/32" drill bit, drill (4) mounting holes into the defrost duct (See Photo 4, below).
4. Install the defrost duct brackets onto the defrost duct using (4) #6 x 3/8" screws (See Photo 5, below).
5. Place the defrost duct assembly into position on the dash, and mark the OEM foam where it is in contact with the defrost duct. Remove the defrost duct and trim the OEM foam from the marked area (See Photo 6, below).
6. Apply the 1/8" x 1/2" x 8" sealing foam to the trimmed area to create a seal for the defrost duct (See Photo 7, below).
7. Install the defrost duct assembly and OEM dash clips onto the dash using the OEM screws (See Photo 8, below).

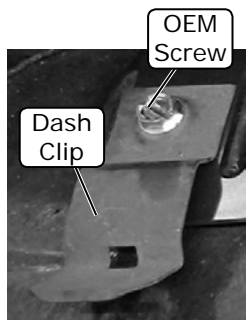

Photo 1

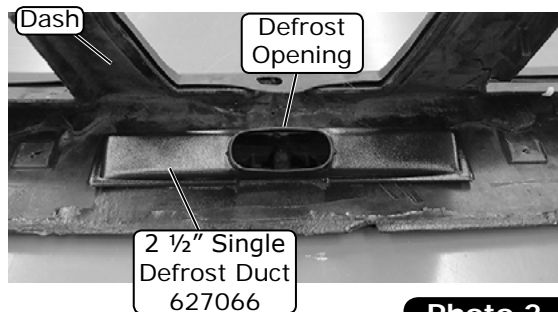

Photo 2

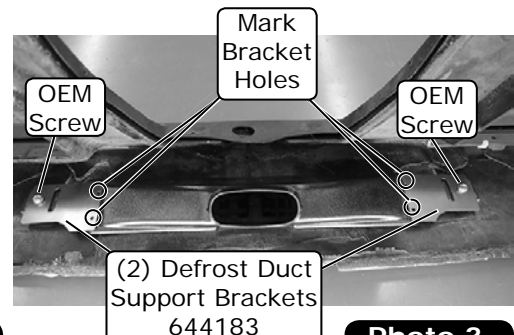

Photo 3

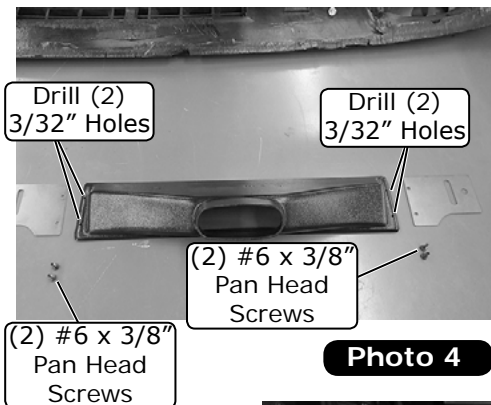

Photo 4

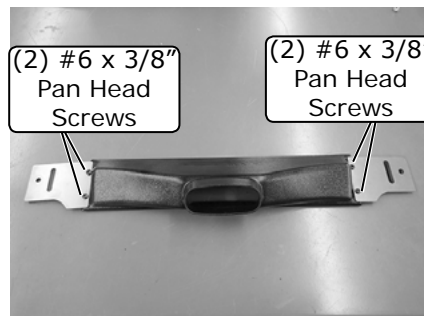

Photo 5

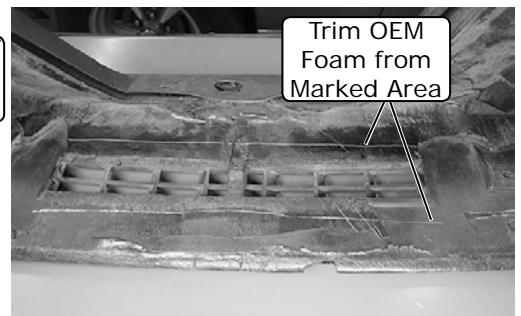

Photo 6

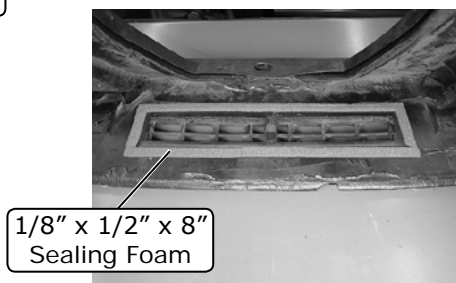

Photo 7



Photo 8



www.vintageair.com

Driver and Passenger Side OEM Louver Modification

1. Remove the driver and passenger side OEM louvers from the dash (See Photo 1, below).
2. Cut and remove 2 5/8" off the OEM louvers (See Photos 2 and 3, below).
3. Install a 2 1/2" hose adapter onto the driver and passenger side OEM louver housings as shown in Photo 4, below.
4. Drill (3) pilot holes using a 3/32" drill bit, and install (3) #6 x 3/8" pan head screws into the hose adapter (See Photo 5, below).
5. Reinstall the louvers into the dash using the OEM hardware.

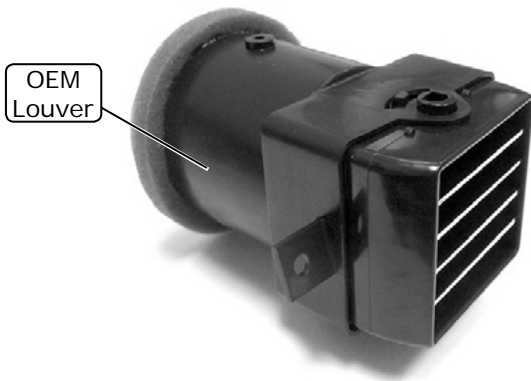

Photo 1

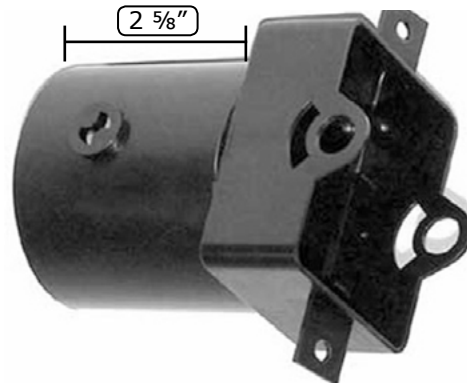

Photo 2

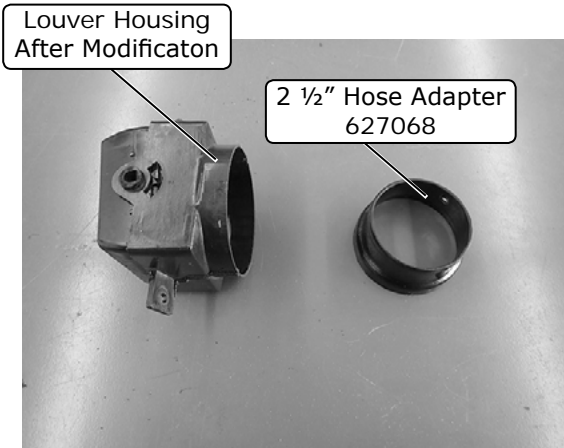

Photo 3

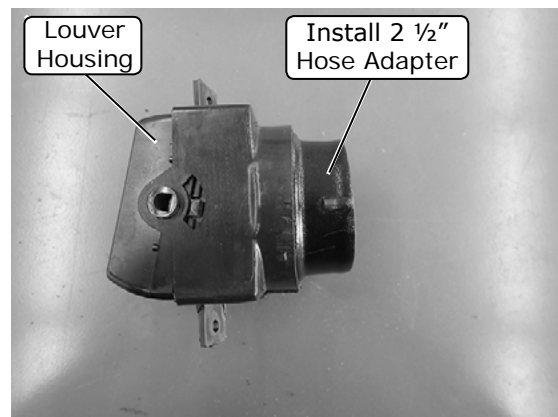

Photo 4

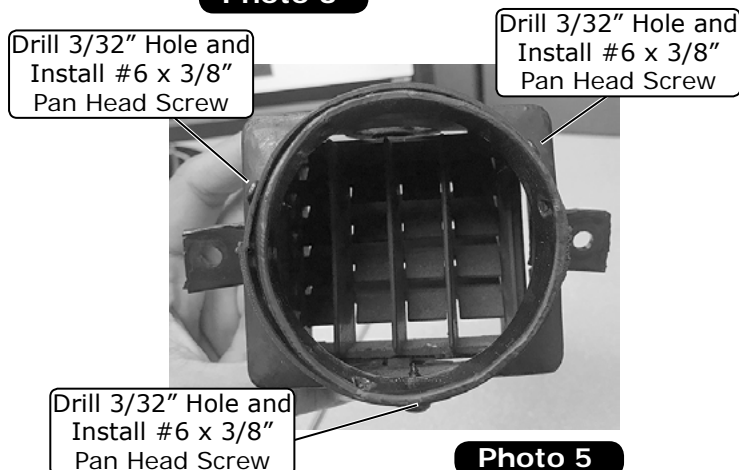

Photo 5



www.vintageair.com

Center Louver Hose Adapter Installation

1. Cut to fit and apply the 1/8" x 1/2" x 8" sealing foam to the bottom of the 2 1/2" center louver hose adapter (See Photo 1, below). **NOTE: The bottom of the hose adapter has cutouts.**
2. Install (2) S-clips onto the top of the hose adapter (See Photo 2, below). **NOTE: Install the longer side of the S-clip onto the outside of the hose adapter.**
3. Install the hose adapter assembly onto the OEM louver housing (See Photo 3, below).

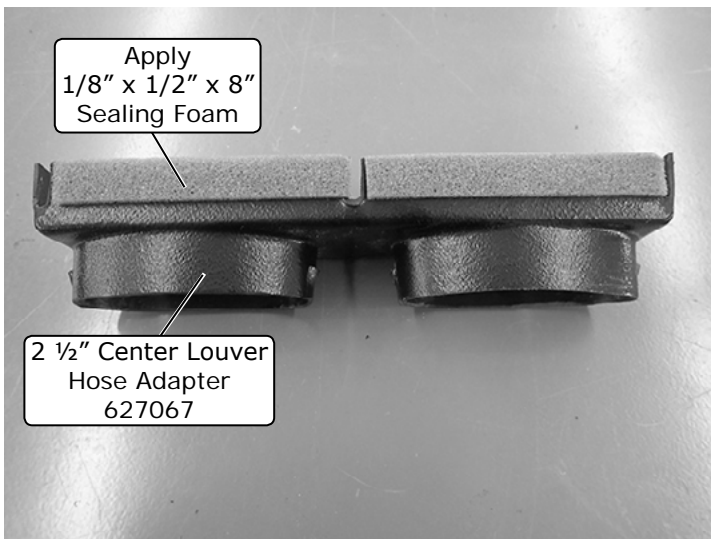

Photo 1

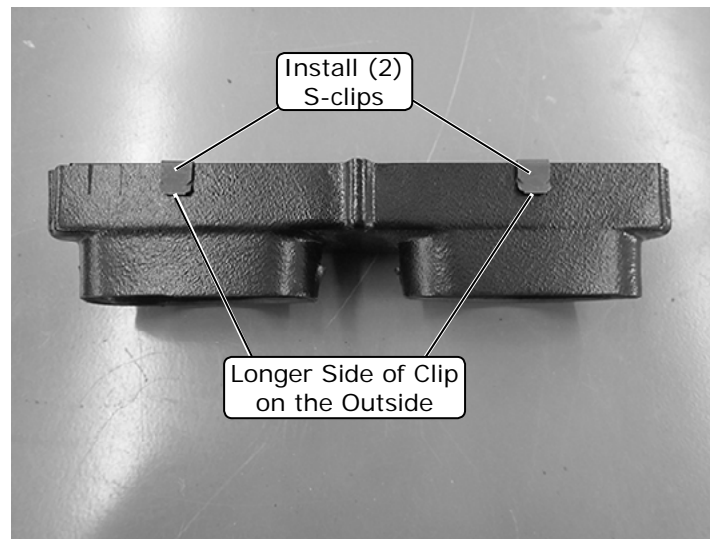

Photo 2

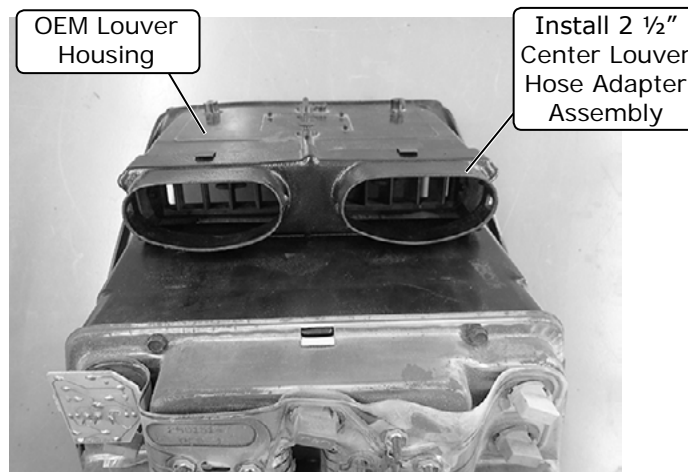

Photo 3



www.vintageair.com

Firewall Modification

NOTE: In order to reinstall the new firewall cover, heater hardlines and A/C hoses, the firewall will require a modification. Perform the following:

1. Remove the OEM riveted nut plates from the firewall in the engine and passenger compartments (discard) (See Photos 1 and 3, below).
2. Temporarily, place the firewall cover over the opening on the firewall, lining up the existing bolt holes using the supplied 1/4-20 x 3/4" bolts to hold the firewall cover in position (See Photo 2, below).
3. Mark the (2) lower mounting holes of the firewall cover onto the firewall (See Photo 2, below).
4. From the passenger compartment, mark the lower corner of the firewall so that the firewall cover weld nuts and AC and heater hose holes clear after trimming (See Photo 3, below).
5. Trace the firewall opening onto the firewall cover. (See Photo 4, below).
6. Remove the firewall cover and drill the marked holes using a 3/8" drill bit. Cut and remove the marked lower portion of the firewall (See Photo 5, below).

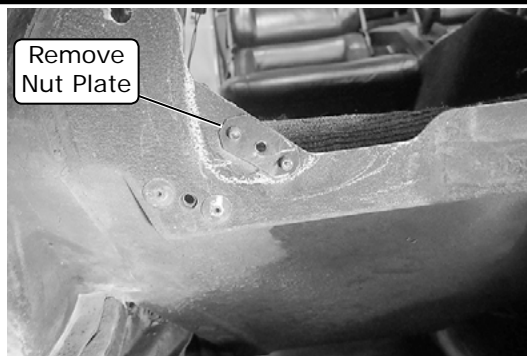

Engine Compartment View **Photo 1**

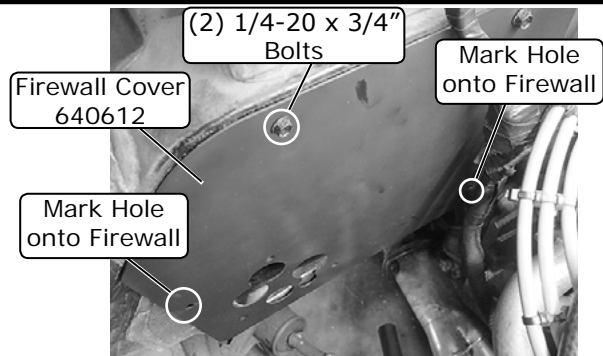
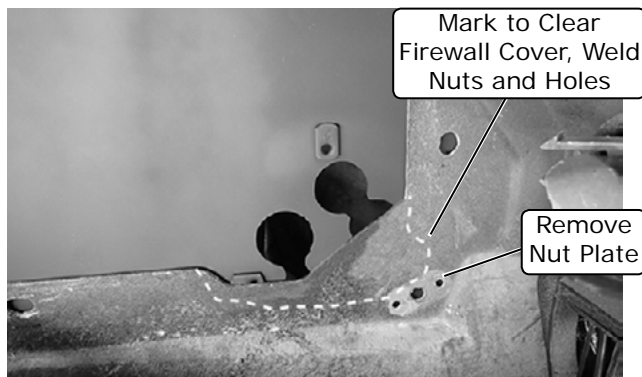

Photo 2



Passenger Compartment View **Photo 3**

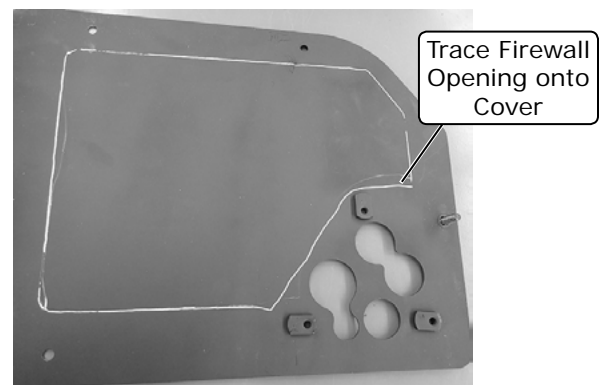

Photo 4



Photo 5



www.vintageair.com

Evaporator Preparation

1. On a work bench, install the evaporator bracket onto the evaporator using (3) 1/4-20 x 1/2" bolts (supplied on sub case) (See Photo 1, below).
2. Loosely install the (2) heater hardlines with properly lubricated O-rings (See Photo 2 and Lubricating O-rings, below). **NOTE: When removing caps from the sub case, BE CAREFUL! The sub case is shipped under pressure.**
3. Install (3) 1/4-20 x 1 1/2" studs into the evaporator bracket approximately 1/4" in depth (See Photo 3, below).
4. Place the firewall cover over the studs and adjust the hardlines as needed (See Photo 4, below).
5. Remove the firewall cover, and tighten the hardlines.

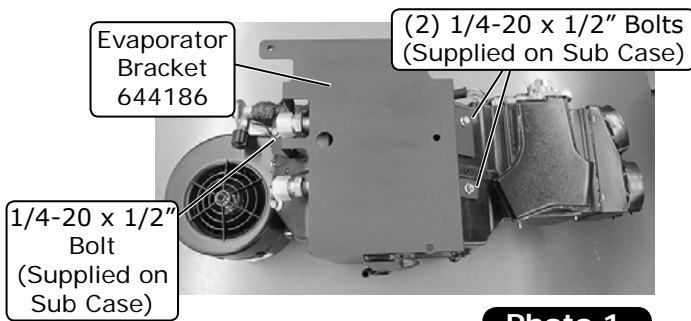

Photo 1

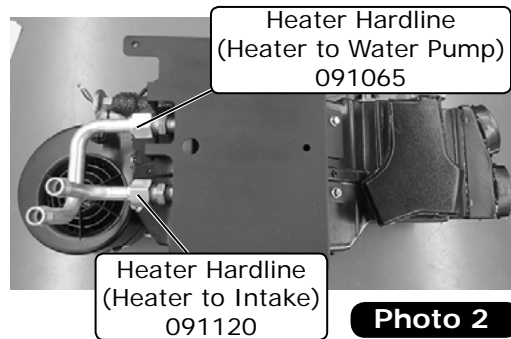

Photo 2

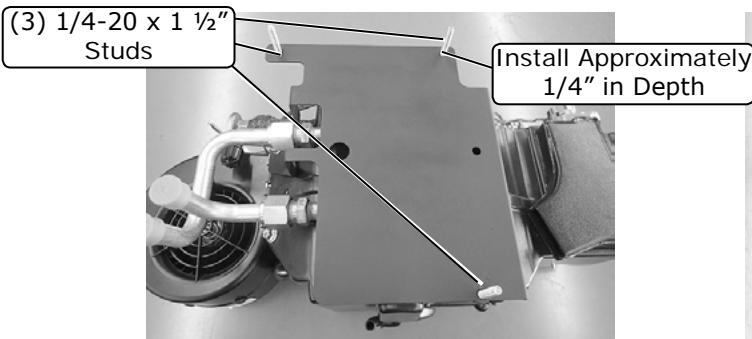

Photo 3

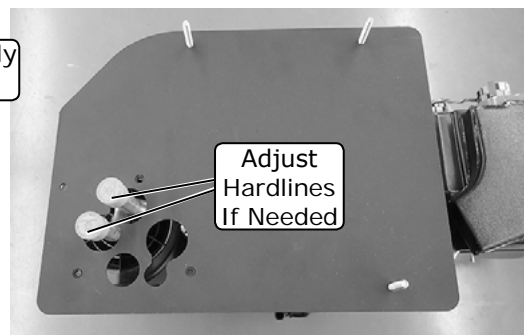
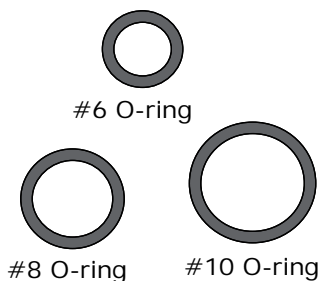
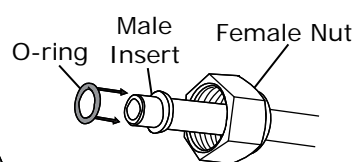

Photo 4

Lubricating O-rings



NOTE: Standard torque specifications:
 #6: 11 to 13 ft-lb.
 #8: 15 to 20 ft-lb.
 #10: 21 to 27 ft-lb.



For a proper seal of fittings: Install supplied O-rings as shown, and lubricate with supplied oil.

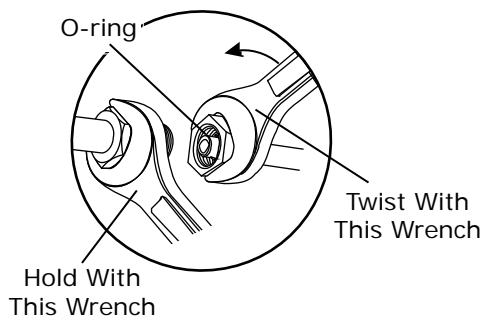
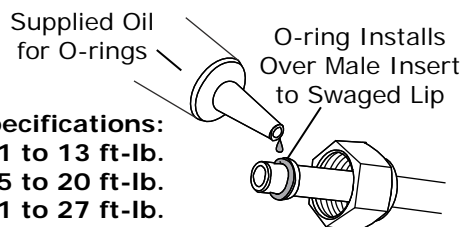



www.vintageair.com

Evaporator Installation

NOTE: For proper system operation, Vintage Air recommends using heat blocking insulation in the area around the evaporator unit (firewall, kick panel, inner cowl, firewall cover). Due to tight clearance for the evaporator unit between the firewall and dash, Vintage Air recommends an insulation thickness of no more than 1/4". To ensure a watertight seal between the passenger compartment and the exterior, for all bolts passing through the firewall, Vintage Air recommends coating the threads with silicone prior to installation.

1. Install the evaporator unit into place and use a block of wood to hold it in position (See Photo 1, below).
2. From the engine compartment, use a 1/4" USS flat washer and 1/4-20 nut with star washer to secure the unit. (See Photo 2, below). **NOTE: Do not place the board directly under the drain outlet, as it may break.**
3. Loosely install the dash bracket onto the evaporator using (2) 1/4-20 x 1/2" bolts (supplied on sub case) (See Photo 3, below).
4. Level the unit left-right and fore-aft (See Photo 4, below). **NOTE: To ensure proper drainage, it is very important that the evaporator is level.**
5. Using the dash bracket as a template, mark the mounting hole (See Photo 5, below). Remove the dash bracket from the unit, and drill a 1/4" hole (See Photo 6, below).
6. Reinstall the evaporator dash bracket. From the engine compartment, install a 1/4-20 x 3/4" hex bolt through the cowl and into the dash and bracket (See Photo 7, below).
7. Tighten the (2) 1/4-20 x 1/2" bolts on the dash bracket.

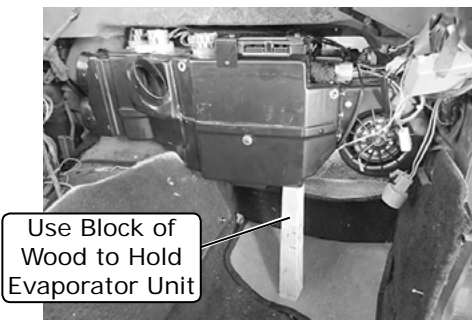

Photo 1

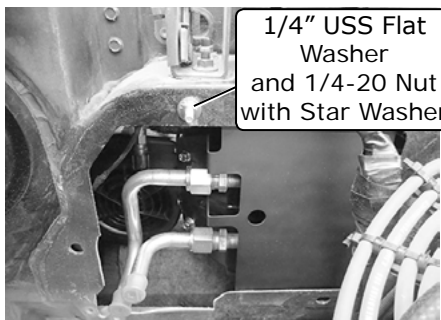

Photo 2

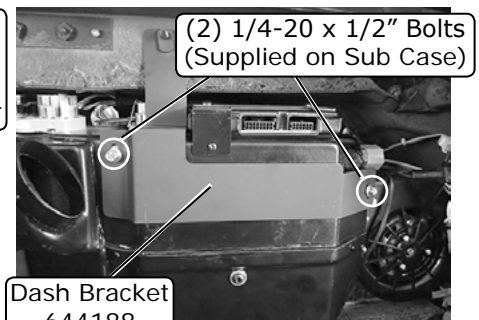

Photo 3



Photo 4



Photo 5

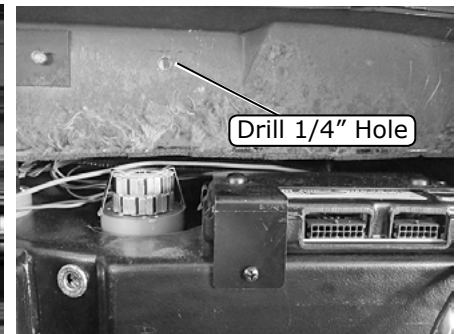
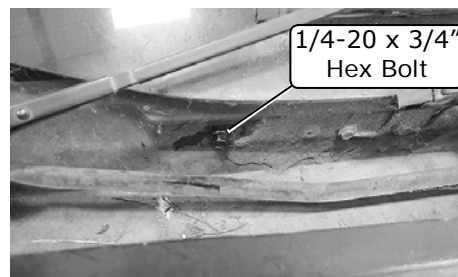

Photo 6



Engine Compartment View

Photo 7



www.vintageair.com

Evaporator A/C Hose Installation

1. Route the 90° fitting of the #10 compressor/evaporator A/C hose through the firewall opening, under the evaporator blower (See Photo 1, below).
2. Install the 90° fitting of the #10 A/C hose onto the #10 fitting of the evaporator unit using a properly lubricated #10 O-ring (See Lubricating O-rings, Page 13, and Photo 2, below). **NOTE: After installing the #10 compressor/evaporator A/C hose, wrap all exposed metal with the supplied press tape (See Photo 3, below).**
3. Route the straight fitting of the #6 drier/evaporator A/C hose through the firewall opening, under the heater hardlines (See Photo 1, below).
4. Install the straight fitting of the #6 drier/evaporator A/C hose onto the expansion valve on the evaporator unit using a properly lubricated #6 O-ring (See Lubricating O-rings, Page 13, and Photo 4, below). **NOTE: Do not fully tighten at this time.**
5. Route the other end of the #6 A/C hose to the #6 condenser hardline and ensure proper clocking of the 45° hose fitting (See Photo 5, below).
6. Once the clocking of the 45° fitting has been checked, fully tighten the #6 A/C hose straight fitting on the expansion valve.

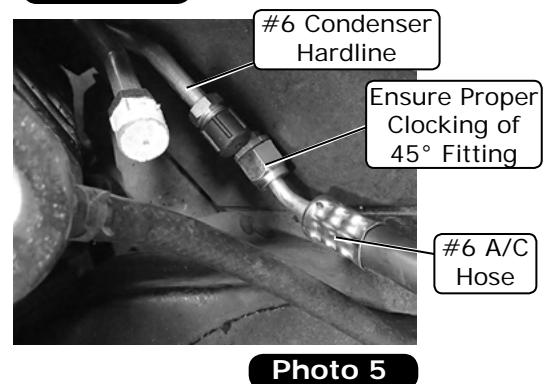
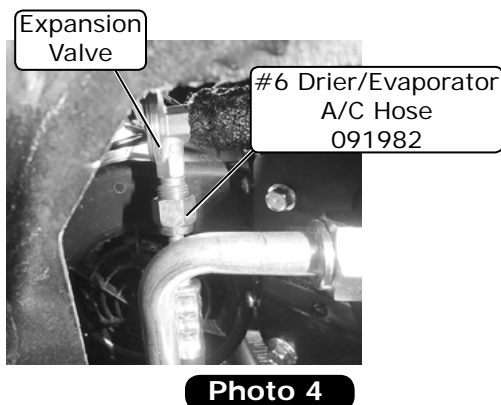
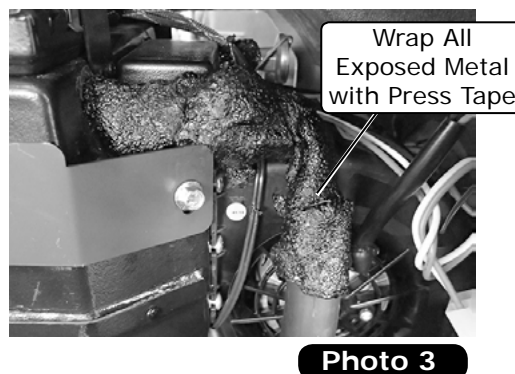
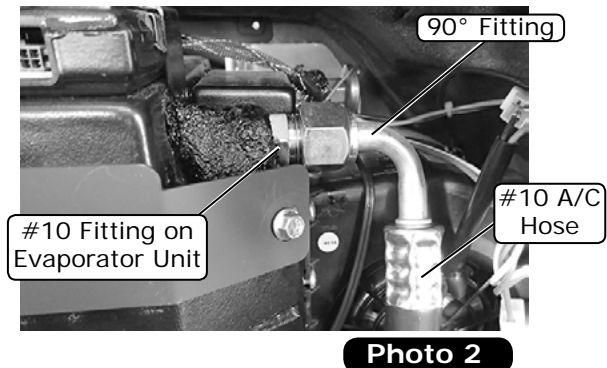
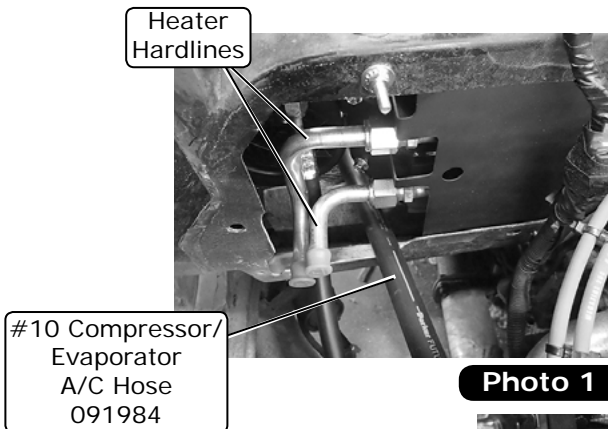



www.vintageair.com

Firewall Cover

1. On a workbench, install a 1/4-20 x 3/4" bolt into the firewall cover with a 3/16" push-on ring as shown in Photo 1, below.
2. Apply insulation to the marked area of the firewall cover (See Photo 2, below).
3. Remove the 1/4-20 nut with star washer and 1/4" USS flat washer from the stud on the firewall (retain) (See Photo 3, below). **NOTE: This hardware will be reused.**
4. Apply a bead of silicone to the mating surface of the firewall and firewall cover (See Figure 1, below).
5. Route the #10 and #6 A/C hoses through the firewall cover. Install the firewall cover over the (3) 1/4-20 x 1 1/2" studs (See Photo 4, below). **NOTE: Temporarily remove the service port cap on the #10 A/C hose to route through the firewall cover. Reinstall the cap after installation to avoid contaminants.**

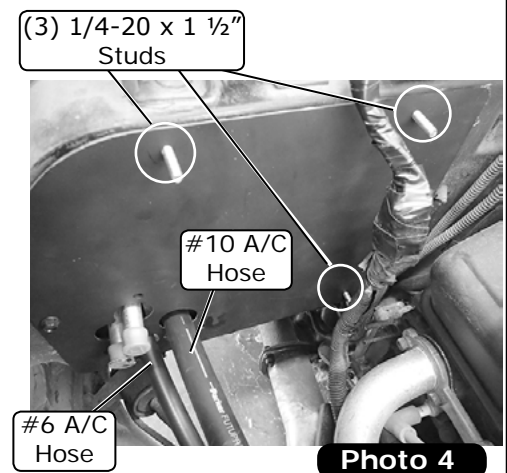
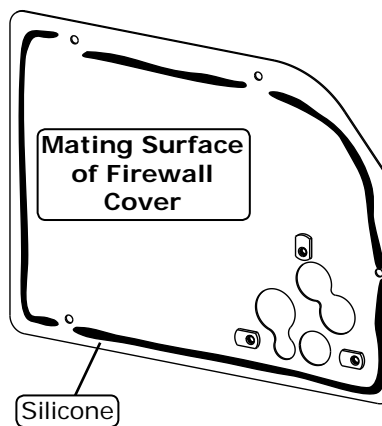
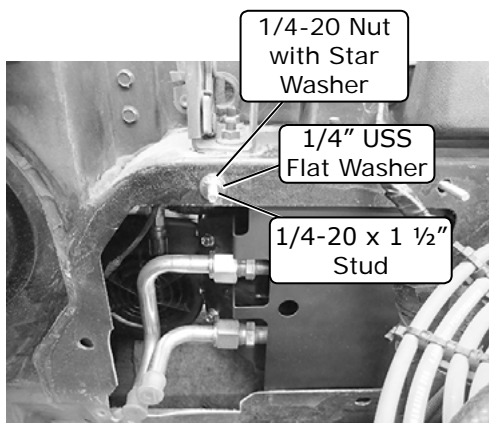
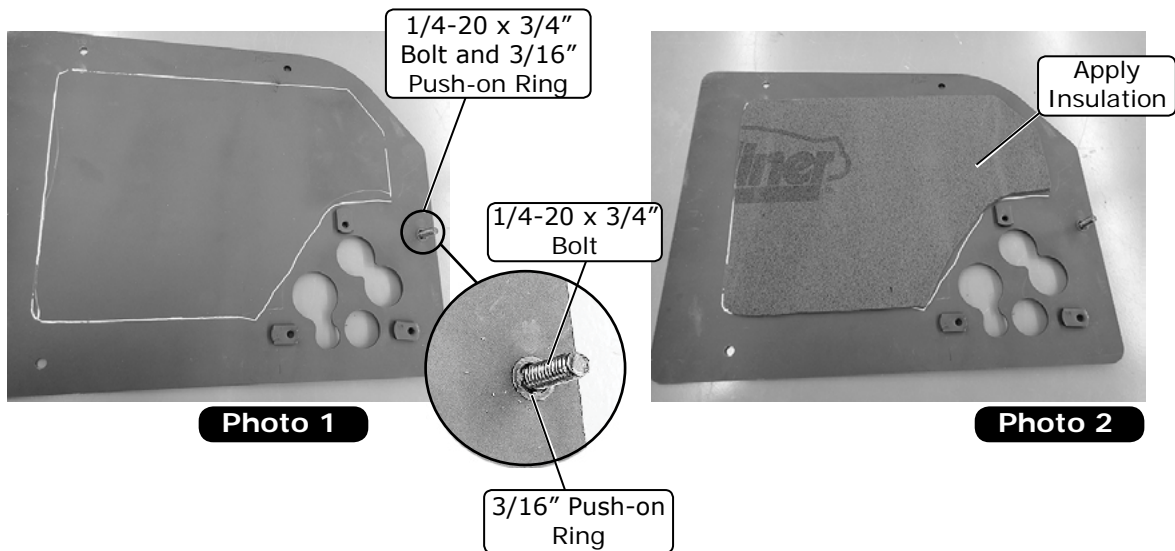



www.vintageair.com

Firewall Cover (Cont.)

6. Replace the (3) 1/4-20 x 1 1/2" studs with (3) 1/4-20 x 3/4" hex bolts (See Photo 5, below). **NOTE: Do not fully tighten the bolts at this time.**
7. Install the previously removed 1/4" USS flat washer and 1/4-20 nut with star washer onto the last bolt on the firewall cover in the passenger compartment (See Photo 6, below).
8. Ensure the evaporator unit is still leveled left-right and fore-aft (See Photo 7, below).
9. Fully tighten the (3) 1/4-20 x 3/4" hex bolts on the firewall cover.

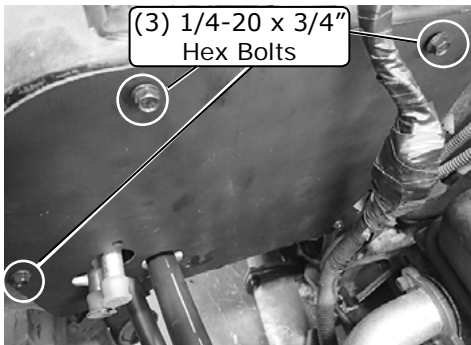

Photo 5



Photo 6



Photo 7

Firewall Rubber Boot and Evaporator Firewall Ring Installation

NOTE: Remove the heater hardline caps for this step and replace when completed.

1. Route the #10 and #6 A/C hoses through the rubber boot and slide it into position on the firewall cover (See Photo 1, below). **NOTE: Soapy water may be used to ease installation of the hoses through the boot, but be sure the A/C hoses are capped to prevent water from getting inside.**
2. Route the #10 and #6 A/C hoses through the evaporator firewall ring and secure it to the firewall using (3) 1/4-20 x 3/4" hex bolts (See Photos 2 and 3, below).

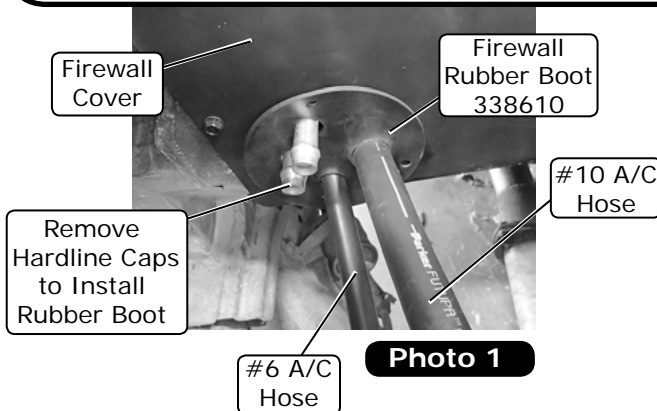

Photo 1

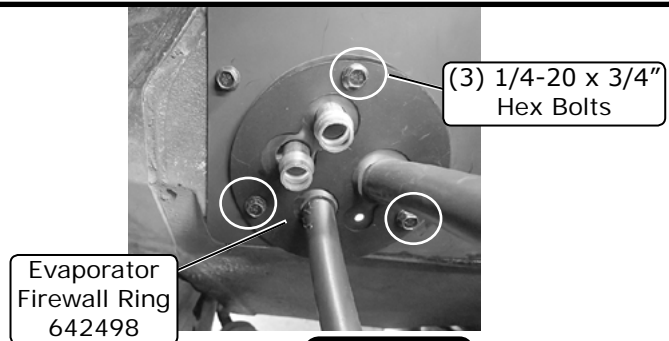

Photo 2

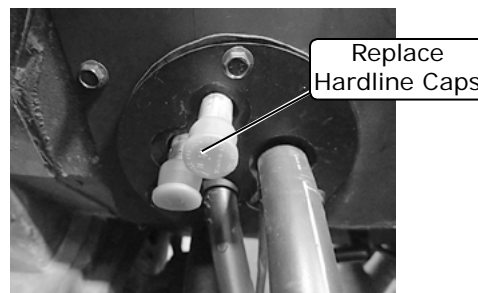

Photo 3



www.vintageair.com

A/C Hose Installation

Standard Hose Kit:

1. Route the #6 drier/evaporator A/C hose along the inner fender, and connect the 45° fitting to the #6 drier hardline with a properly lubricated O-ring (See Lubricating O-rings, Page 13, and Photo 1, below).
2. Connect the #10 A/C hose 45° fitting with service port and a properly lubricated O-ring to the #10 suction port on the compressor (See Lubricating O-rings, Page 13, and Photo 2, below).
3. Connect the #8 A/C hose 135° fitting with service port and a properly lubricated O-ring to the #8 discharge port on the compressor (See Lubricating O-rings, Page 13, and Photo 3, below).
4. Connect the #8 A/C hose 45° fitting and a properly lubricated O-ring to the #8 condenser hardline (See Lubricating O-rings, Page 13, and Photo 4, below).
5. Install a #6 Adel clamp onto the #6 A/C hose, and attach it to the inner fender with a #10 x 1/2" sheet metal screw (See Photo 5, below).

Modified Hose Kit:

1. Refer to separate instructions included with modified hose kit.

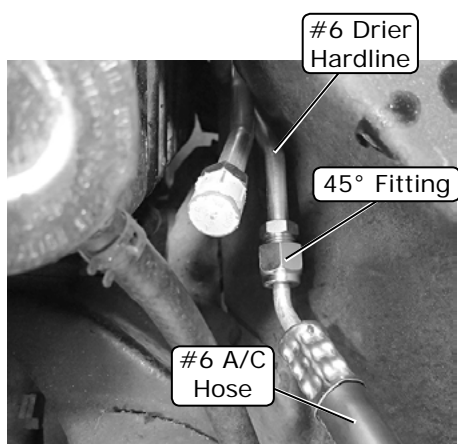

Photo 1

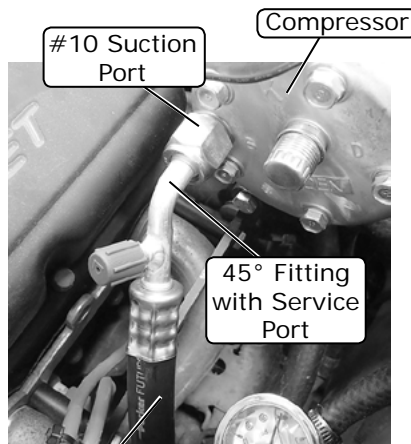

Photo 2

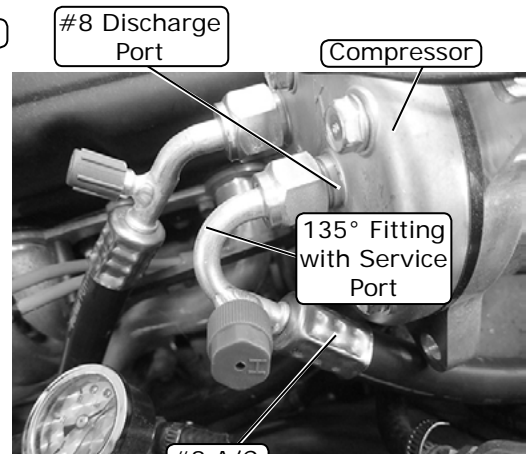

Photo 3

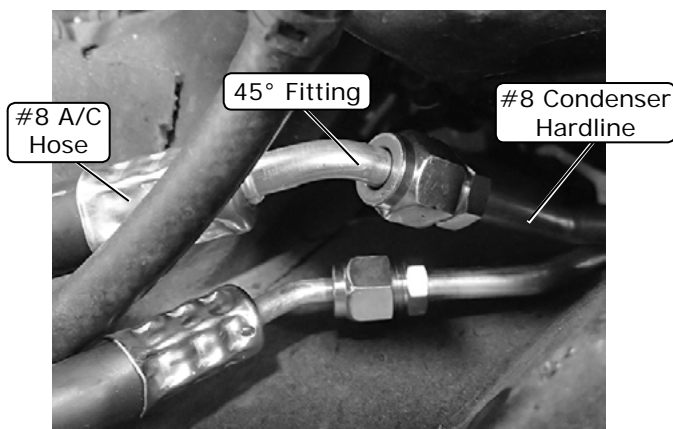

Photo 4

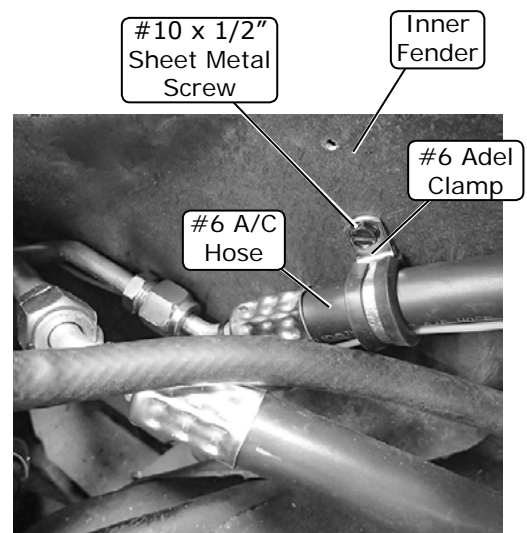

Photo 5



www.vintageair.com

Drain Hose Installation

1. From the passenger compartment, locate the evaporator drain. Mark and drill a 5/8" hole, 3/4" lower and directly in front of the evaporator drain (See Photo 1, below). **NOTE: To ensure a tight fit, do not enlarge the hole to more than 5/8".**
2. Cut the supplied drain hose to 7 1/2" long, and install the 1/2" drain elbow (See Photo 2, below).
3. Install the drain hose through the 5/8" hole on the firewall, then onto the evaporator drain (See Photo 3, below).

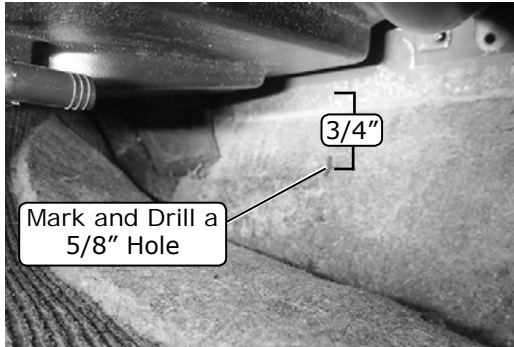

Photo 1

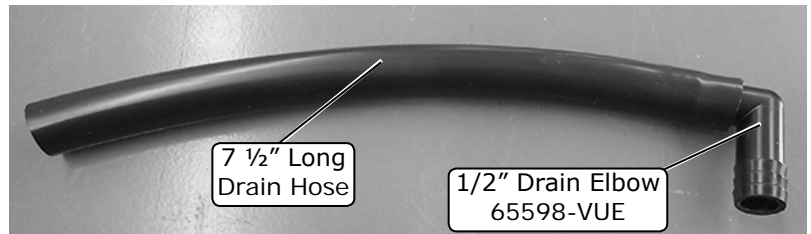

Photo 2

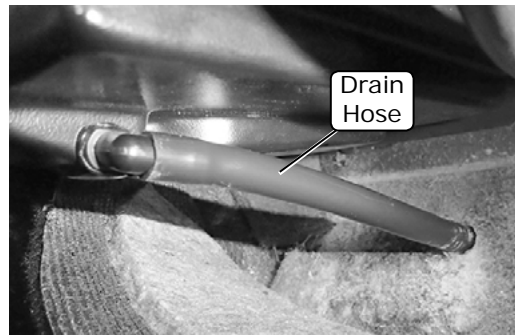

Photo 3

Heater Hose & Heater Control Valve Installation

NOTE: Vintage Air Systems use 5/8" heater connections. On engines equipped with 3/4" hose nipples, these will need to be removed and replaced with 5/8" nipples (not supplied). For water pumps with a cast-in 3/4" heater outlet, a 3/4" x 5/8" reducer fitting (not supplied) or molded hose will need to be installed in the heater hose.

1. Remove the caps from the heater hardlines.
2. Route a piece of heater hose (not provided) from the lower heater hardline to the water pump (See Photos 1 and 2, below). Secure the hose using (2) #12 hose clamps. **NOTE: Rubber hoses must be inserted through rubber boot for a proper seal.**

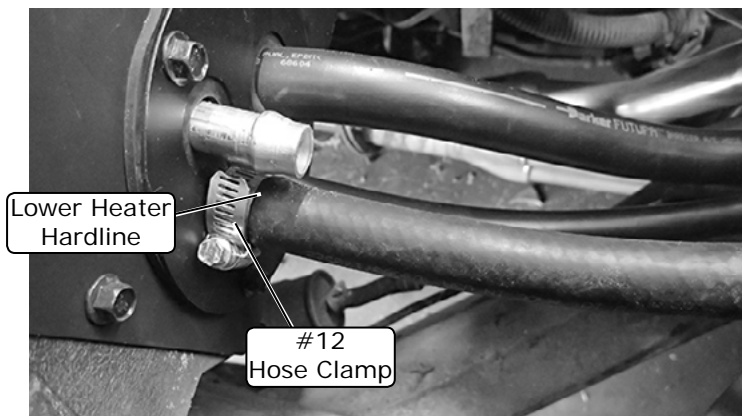

Photo 1

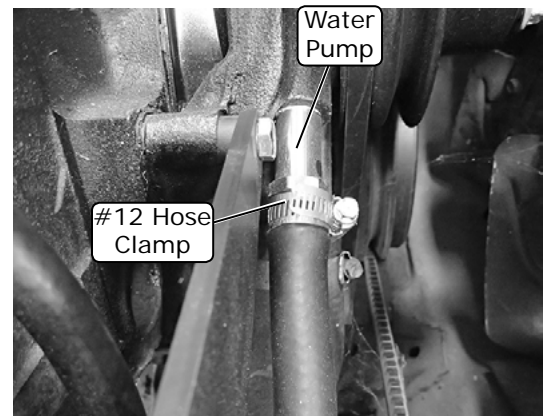

Photo 2



www.vintageair.com

Heater Hose & Heater Control Valve Installation (Cont.)

3. Attach a 5" piece of heater hose (not supplied) to the heater control valve and install it to the upper heater hardline. Secure the hose using (2) #12 hose clamps (See Photo 3, below). **NOTE: Flow direction follows molded arrow on valve.**
4. Install a length of heater hose (not supplied) from the heater control valve to the intake manifold fitting. Secure the hose with (2) #12 hose clamps (See Photos 4 and 5, below).

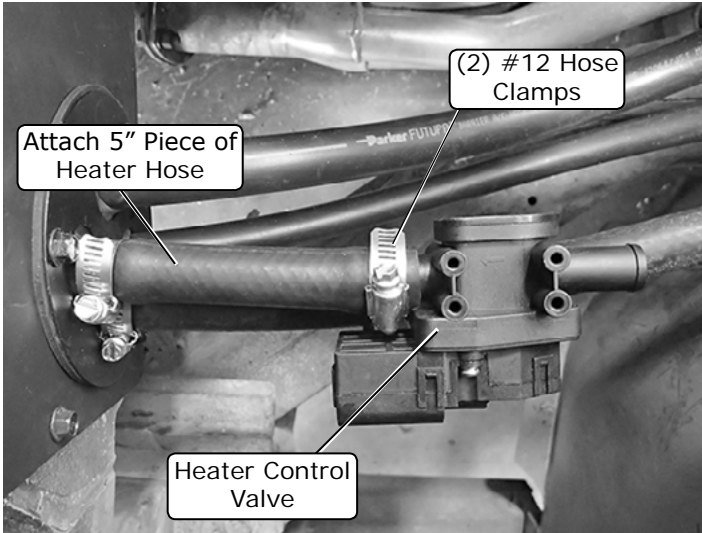

NOTE: Flow Direction Follows Molded Arrow on Valve

Photo 3

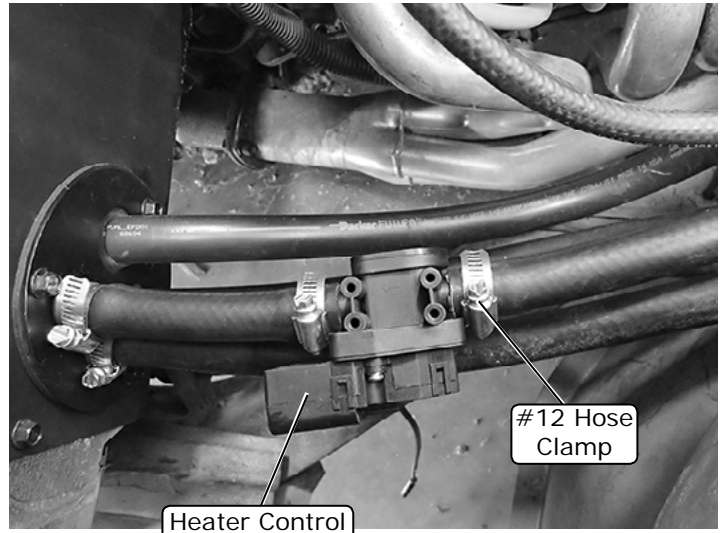

Photo 4



Photo 5

1. Locate the main relay, and enlarge the mounting hole using a 1/4" drill bit (See Photo 1, below).
2. Remove the circuit breaker from the main wiring harness (See Photo 2, below).
3. Attach the main relay to the back of the dash bracket bolt and secure it using a 1/4-20 nut with star washer (See Photo 3, below).
4. Route the blue safety switch wire from the main wiring harness through the evaporator firewall ring, and tie wrap it to the #6 A/C hose (See Photo 4, below).
5. Strip the blue safety switch wire and crimp the supplied 1/4" female terminal onto it. Connect the blue safety switch wire to the safety switch on the drier (See Photo 5, below).
6. Connect the bullet terminal of the compressor lead to the compressor bullet terminal (See Photo 6, below).

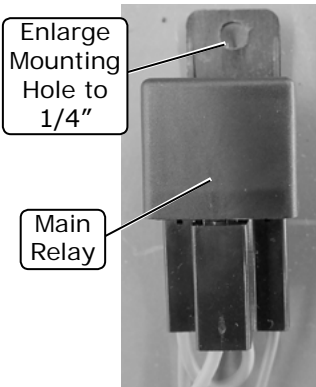

Photo 1

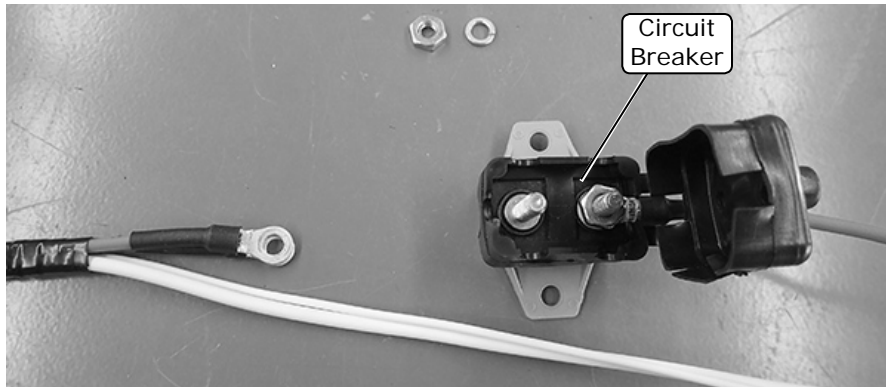

Photo 2

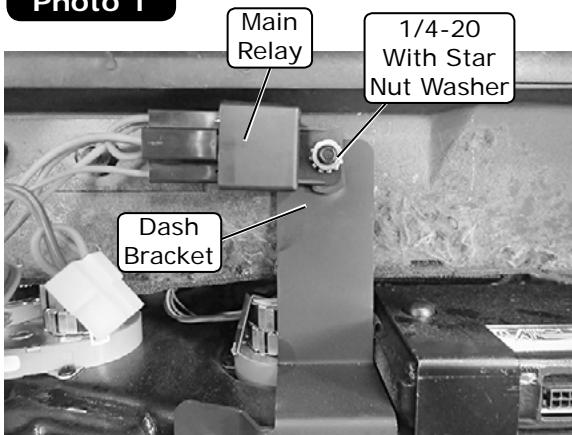

Photo 3

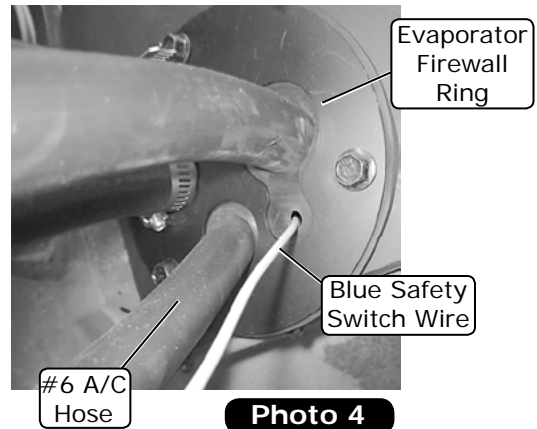

Photo 4

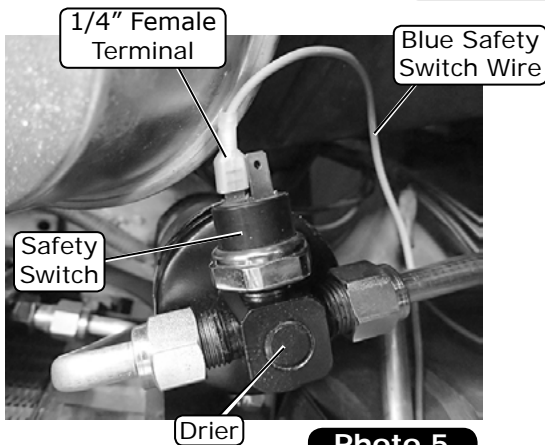

Photo 5

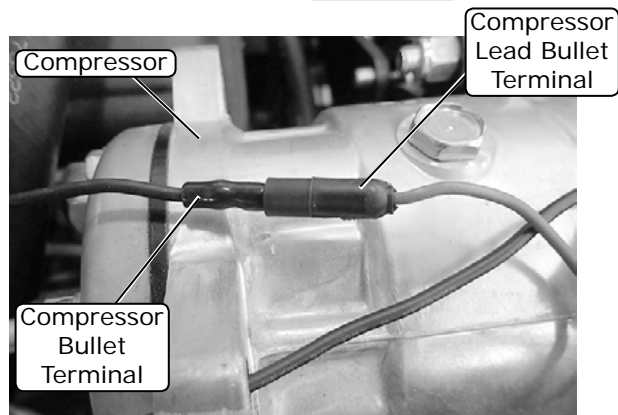

Photo 6

7. Route the compressor lead along the #8 A/C hose and secure it using tie wraps.
8. Connect the 1/4" female terminal of the compressor lead to the safety switch on the drier (See Photo 7, below).
9. Route the heater control valve plug through the evaporator firewall ring and into the passenger compartment (See Photos 8 and 9, below).
10. Connect the heater control valve harness plug and the heater control valve plug together (See Photo 10, below).
11. Ground the eyelet of the heater control valve wiring harness to a suitable ground (See Photo 11, below).
12. Connect the heater control valve harness to the main wiring harness (See Photo 12, below).

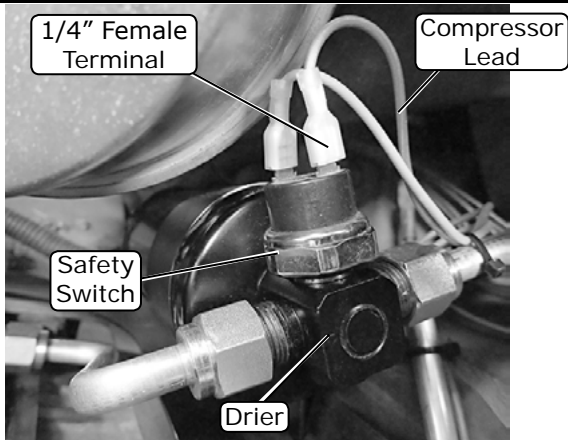

Photo 7

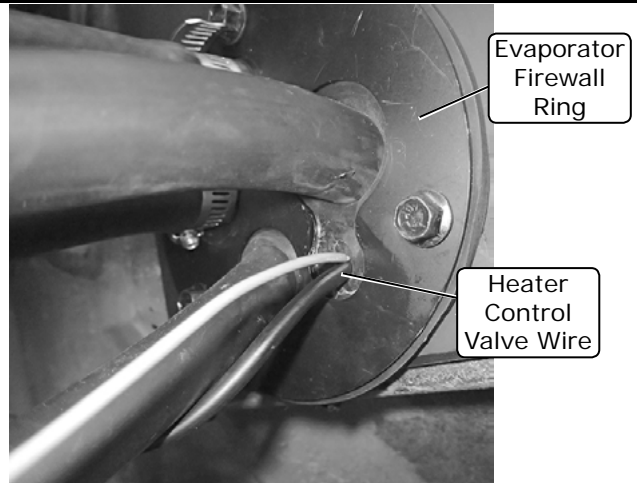

Photo 8



Passenger Compartment View

Photo 9

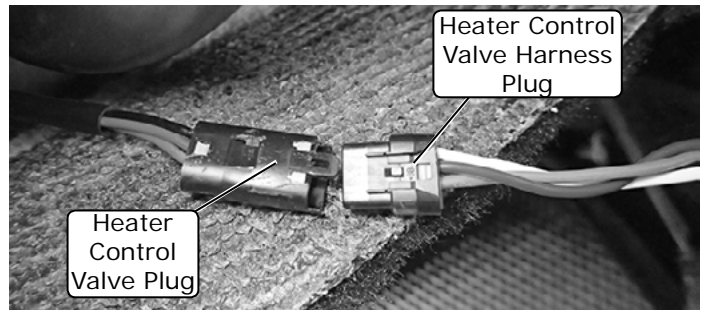

Photo 10

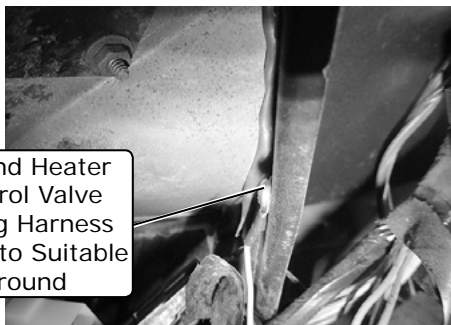

Photo 11

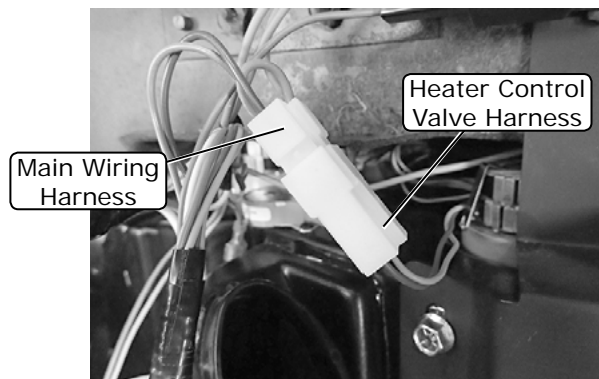

Photo 12



www.vintageair.com

Wiring (Cont.)

13. Connect the blower motor connector to the main harness connector (See Photo 13, below).
14. Connect the main wiring harness to the ECU (See Photo 14, below).
15. The power wire must be extended to reach the battery. Perform the following steps:
 - a) Cut the red power wire connected to the circuit breaker to 40". **NOTE: 54" of wire will be left (See Photo 15, below).**
 - b) Cut the existing eyelets from the red power wires on the main harness.
 - c) Strip the insulation from the red power wires, and crimp the supplied butt connector (See Photos 16 and 17, below).
 - d) Route the 54" of red power wire leftover through the center console, to the battery compartment.
 - e) Strip the insulation from the wire, and crimp the supplied eyelet onto it (See Photo 18, below).

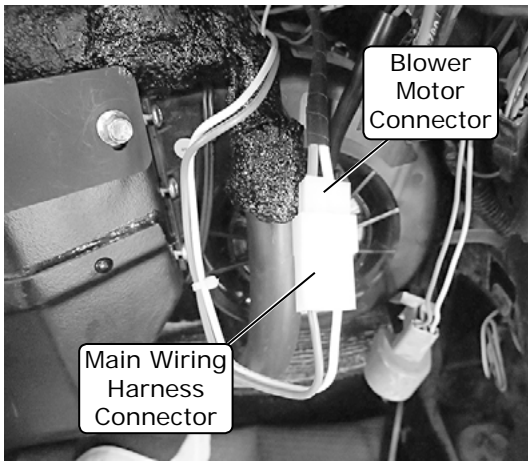

Photo 13

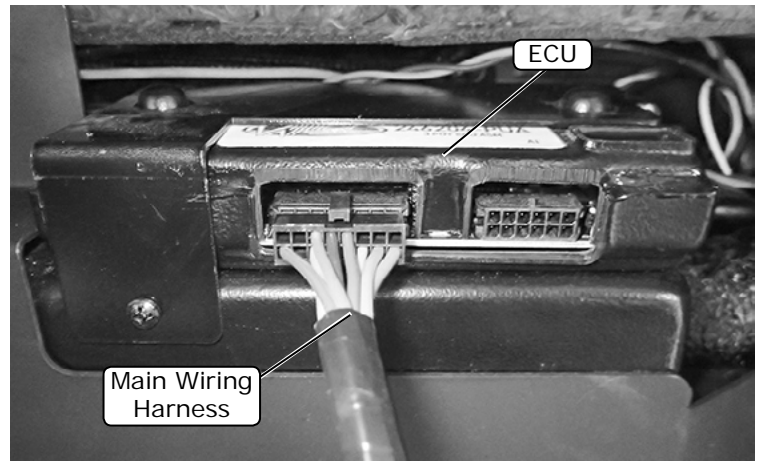

Photo 14

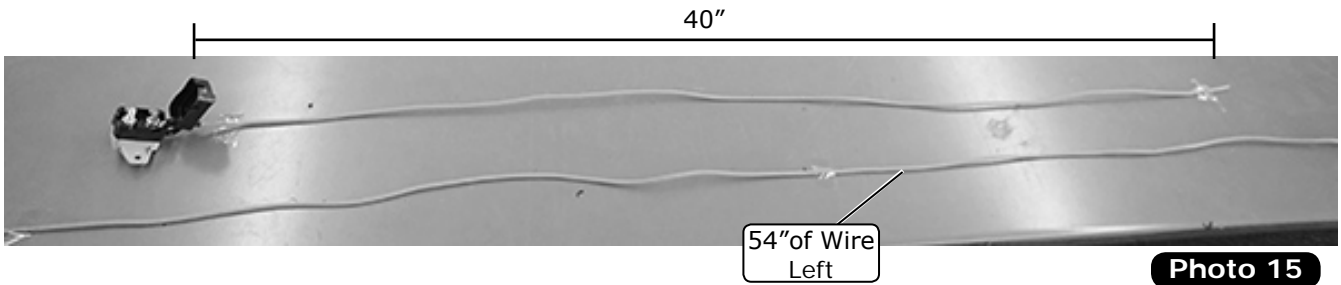

Photo 15

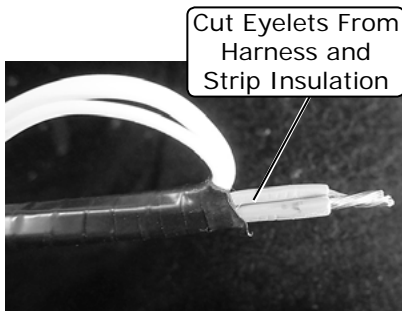

Photo 16

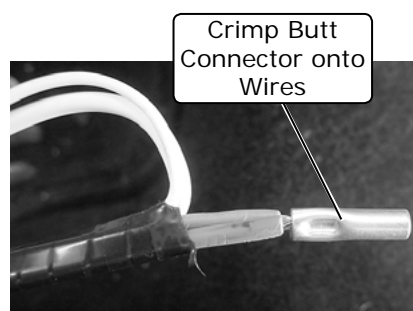

Photo 17

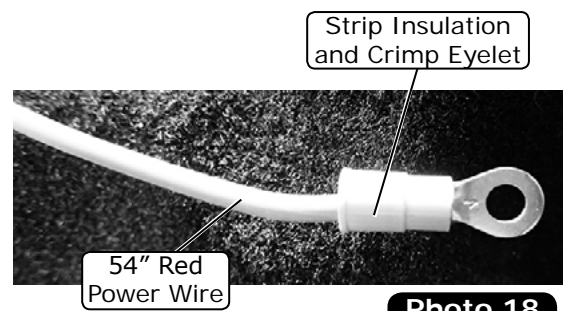

Photo 18



www.vintageair.com

Wiring (Final)

16. Mount the circuit breaker in the battery compartment using (2) #10 x 1/2" sheet metal screws (See Photo 19, below).
17. Attach the 54" red power wire eyelet to the circuit breaker (See Photo 20, below).
18. Slide the supplied heat shrink over the power wire with the butt connector. Strip the insulation and crimp the 54" red power wire into the butt connector (See Photo 21, below).
19. Route the white ground wires through the center console and into the battery compartment.
20. Strip the insulation from the white ground wiring, and crimp the supplied eyelet onto it (See Photo 22, below).
21. Strip the insulation from the single red power wiring and crimp the supplied eyelet (See Photo 23, below).
22. Route the violet wire to the vehicles fuse panel.
23. Attach the violet wire to a 12 volt key-on power source.
24. Attach the tan wire to the dash back lighting (12 volt).

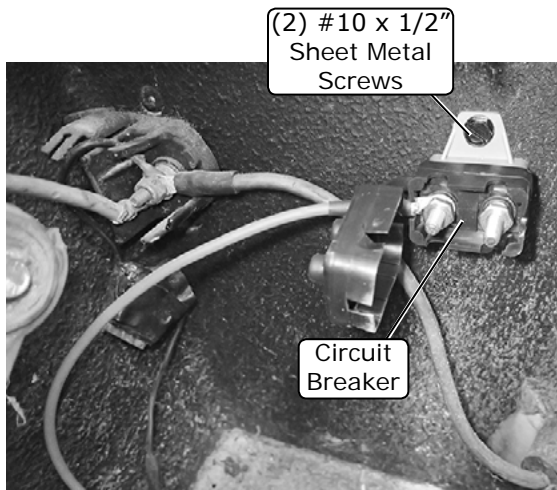

Photo 19

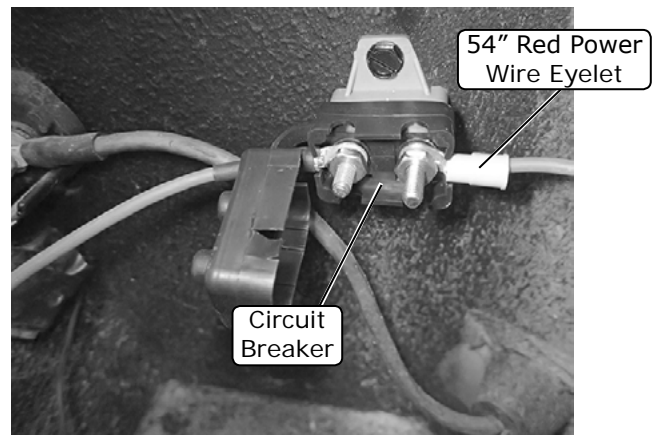

Photo 20

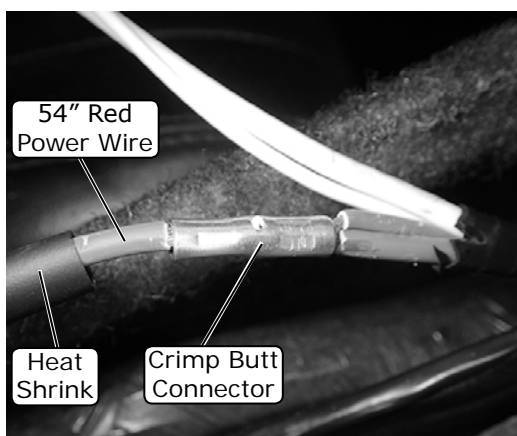

Photo 21

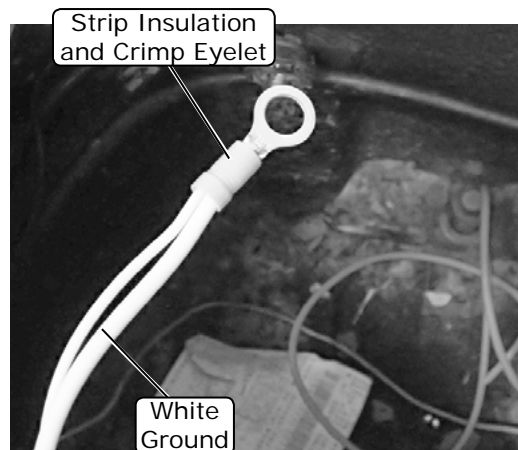

Photo 22

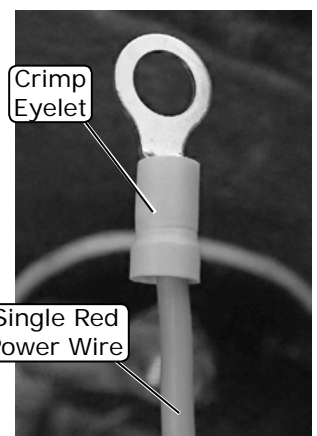

Photo 23



www.vintageair.com

Evaporator Sub Case

ECU Module

Press Tape

Firewall Cover

Heater Control Valve

#10 A/C Suction Hose (Compressor/Evaporator)

#6 A/C Hose (Drier/Evaporator)

#8 A/C Discharge Hose (Compressor/Condenser Hardline)

Hose Routing

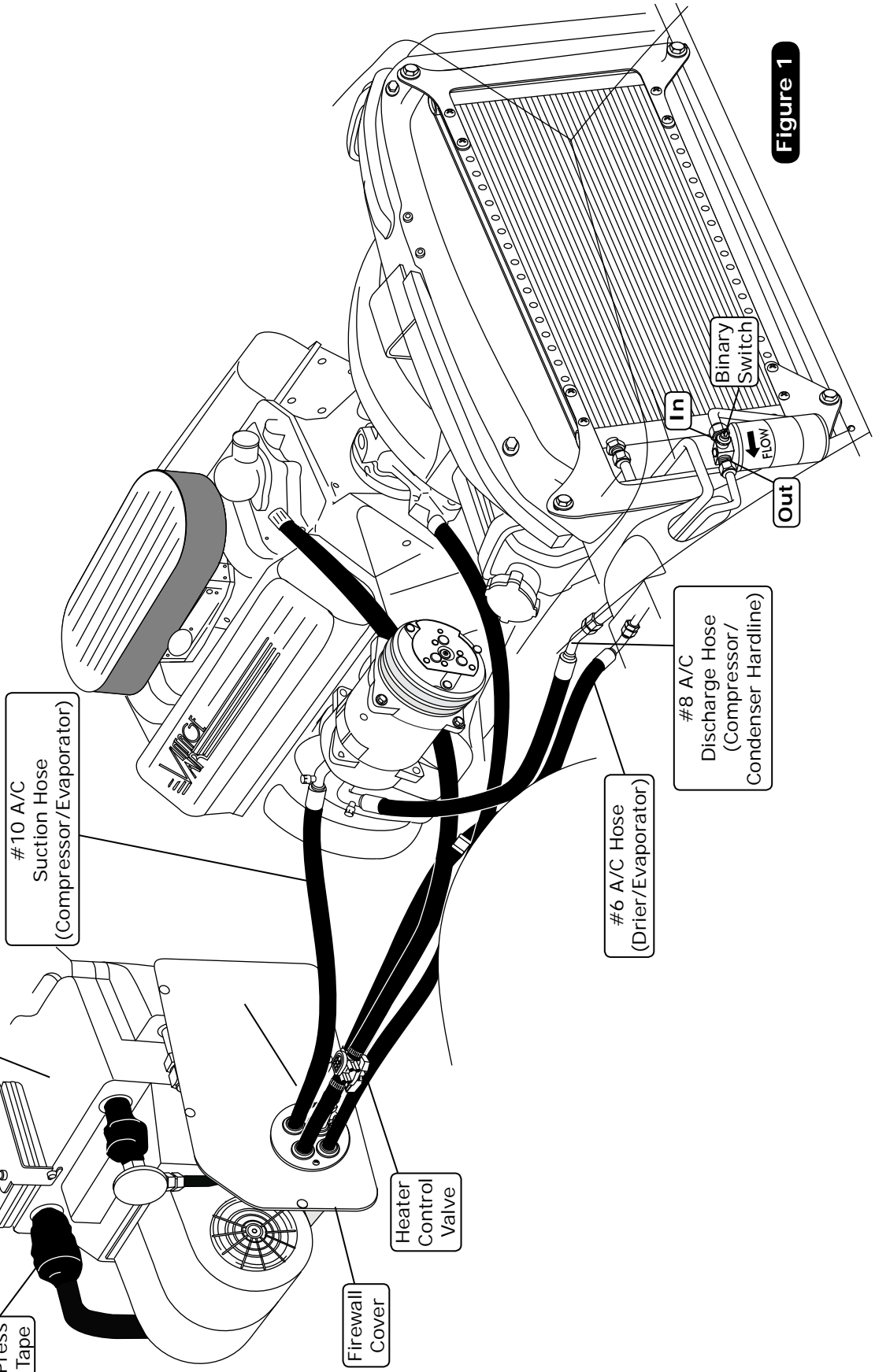

Figure 1



www.vintageair.com

Final Steps

1. Reinstall dash into the vehicle (connecting all wiring and plugs, previously removed speakers, gauges, light switch, radio, etc.)
2. Install the duct hoses as shown in Figure 1, Page 27.
3. Route (2) 11" tie wraps through the steering column mounting bracket as shown in Photo 3, below.
4. Secure the 2 1/2" under dash duct to the bracket using the tie wraps (See Photo 4, below).
5. Reinstall the center dash assembly.
6. Plug the control panel harness into the ECU module on the sub case as shown in Photo 1, below.
7. Install the supplied glove box using (6) OEM screws (See Photo 2, below).
8. Reinstall all previously removed items.
9. Fill the radiator with at least a 50/50 mixture of approved antifreeze and distilled water. It is the owner's responsibility to keep the freeze protection at the proper level for the climate in which the vehicle is operated. Failure to follow antifreeze recommendations will cause heater core to corrode prematurely and possibly burst in A/C mode and/or freezing weather, voiding your warranty.
10. Double check all fittings, brackets and belts for tightness.
11. Vintage Air recommends that all A/C systems be serviced by a licensed automotive A/C technician.
12. Evacuate the system for a minimum of 45 minutes prior to charging, and perform a leak check prior to servicing.
13. Charge the system to the capacities stated on Page 4 of this instruction manual.
14. See Operation of Controls procedures on Page 30.

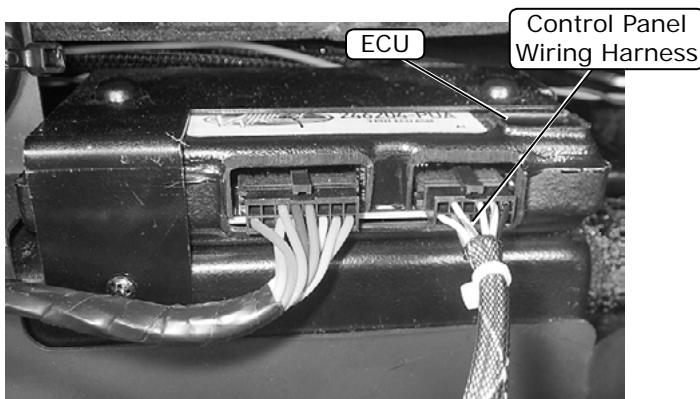

Photo 1

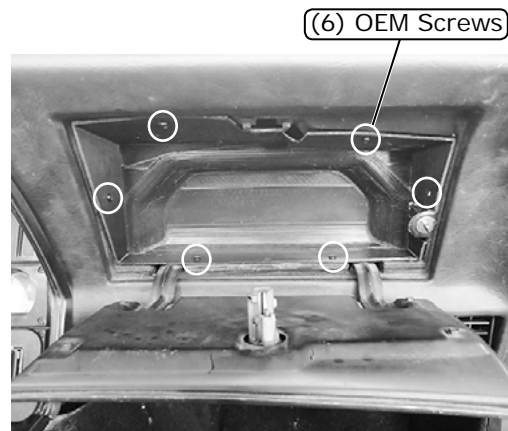

Photo 2

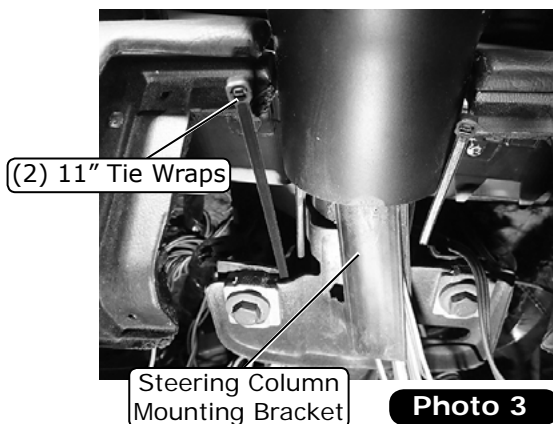

Photo 3

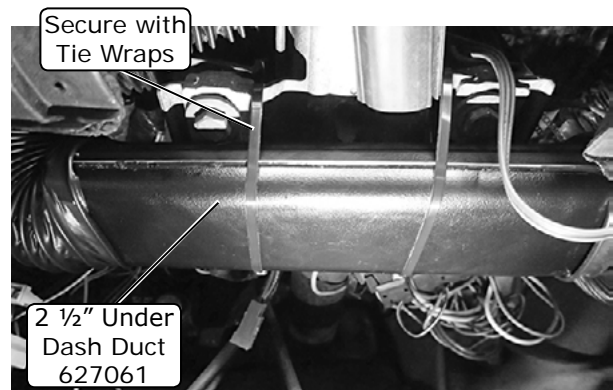

Photo 4



www.vintageair.com

Control Panel & Duct Hose Routing

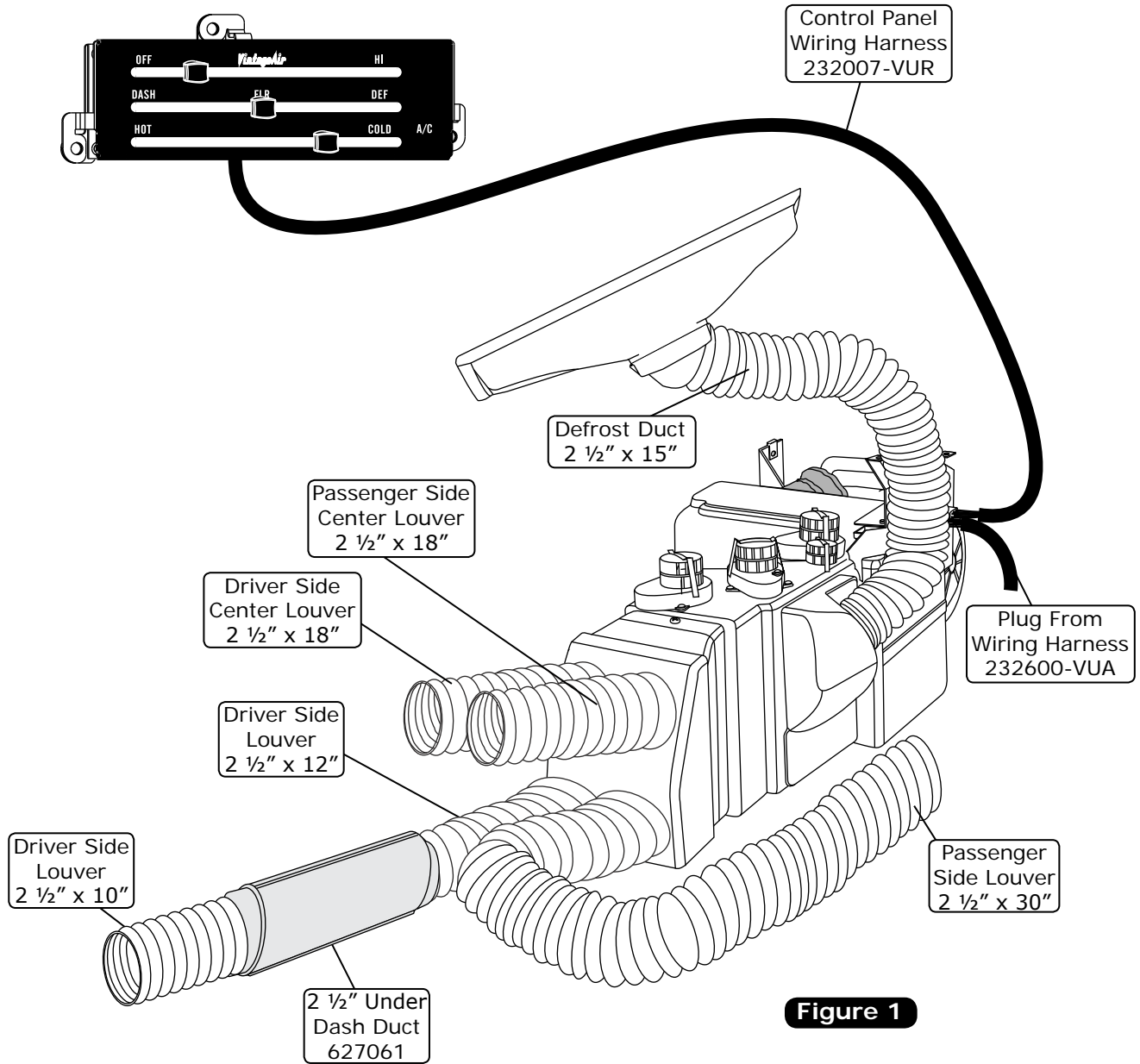

Figure 1



www.vintageair.com

Wiring Diagram

232007-VUR

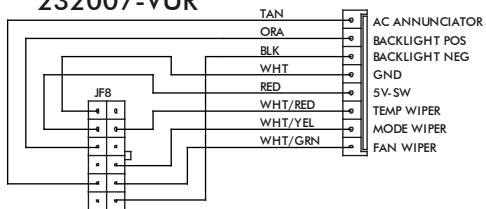

VIEWED FROM WIRE SIDE

232002-VUA

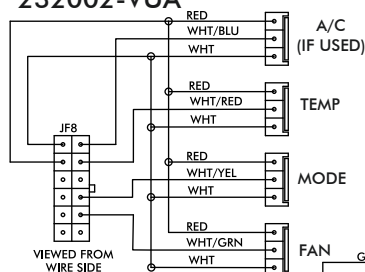

VIEWED FROM WIRE SIDE

PROGRAM

N/A
* DASH LAMP (IF USED)

*** WIDE OPEN THROTTLE SWITCH (OPTIONAL)

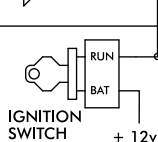

IGNITION SWITCH +12v

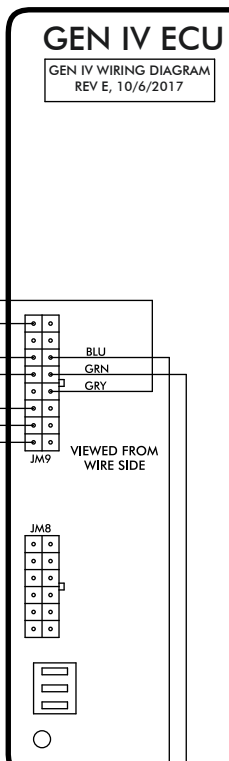

VIEWED FROM WIRE SIDE

PRE-WIRED

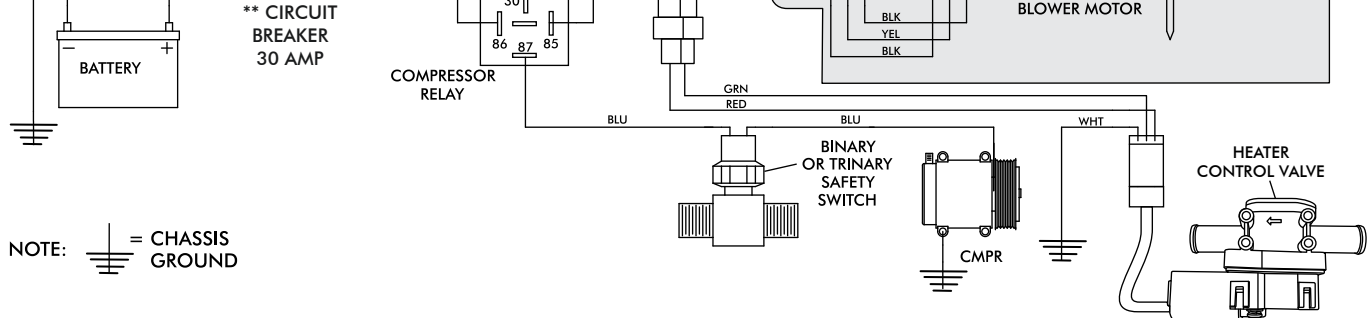
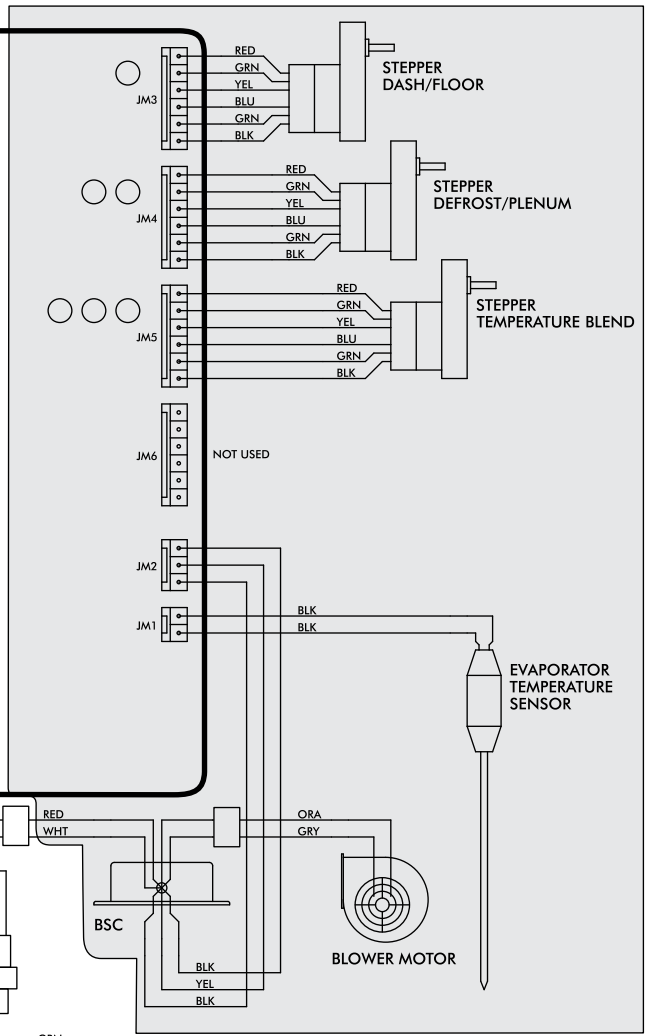

NOTE: = CHASSIS GROUND

- * Dash lamp is used only with type 232007-VUR harness.
- ** Warning: Always mount circuit breaker as close to the battery as possible. (NOTE: Wire between battery and circuit breaker is unprotected and should be carefully routed to avoid a short circuit).
- *** Wide open throttle switch contacts close only at full throttle, which disables A/C



www.vintageair.com

Gen IV Wiring Connection Instruction

WIRING HARNESS

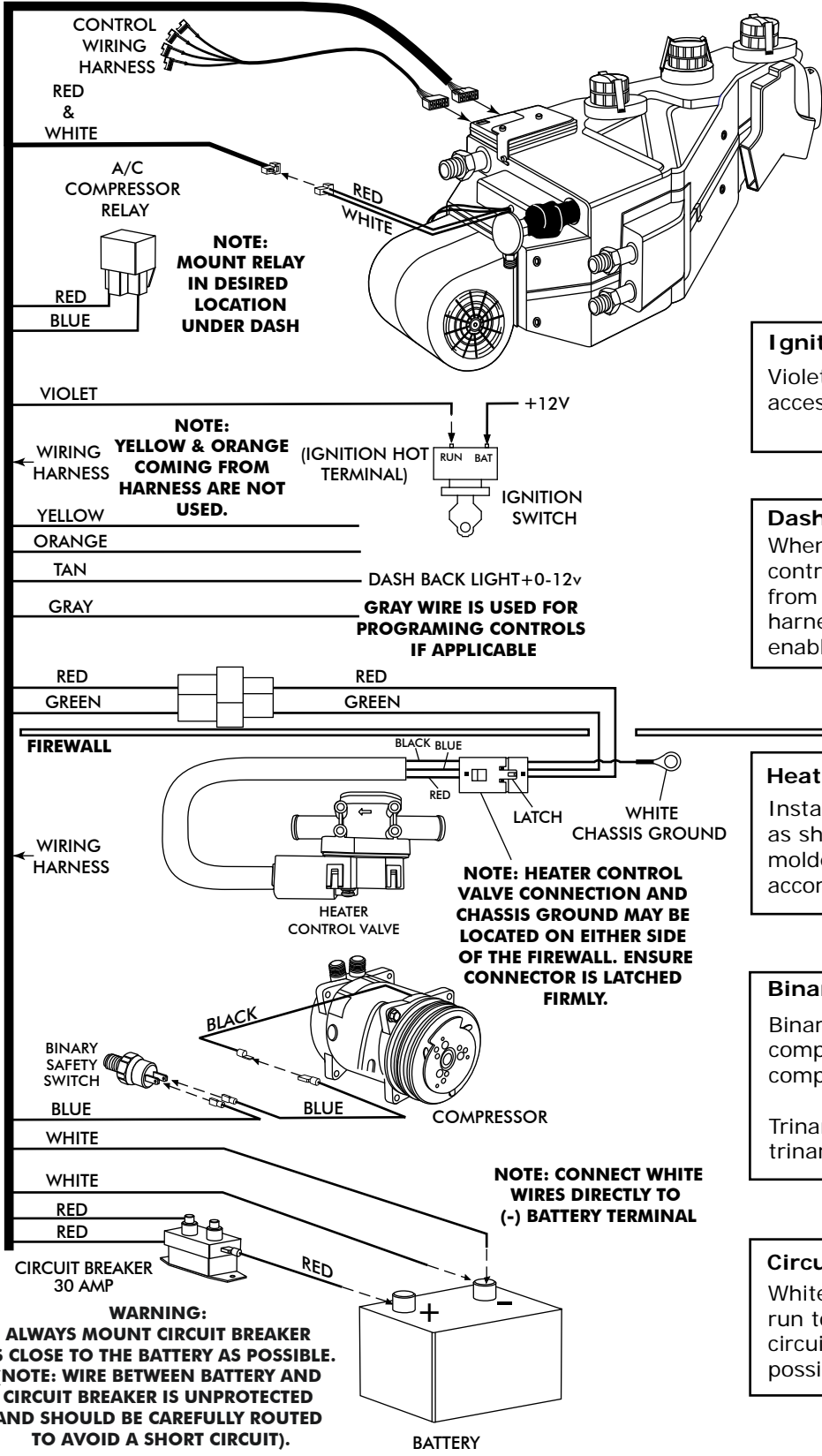

Ignition Switch:
Violet 12V ignition switch source (key on accessory) position must be switched.

Dash Light:
When using a Vintage Air supplied control panel, connect the tan wire from the Gen IV evaporator wiring harness to the factory dash lights to enable panel backlighting.

Heater Control Valve:
Install with servo motor facing down, as shown. Note flow direction arrow molded into valve body and install accordingly.

Binary/Trinary & Compressor:
Binary: Connect as shown (typical compressor wiring). Be sure compressor body is grounded.
Trinary Switch: Connect according to trinary switch wiring diagram.

Circuit Breaker/Battery:
White **must** run to (-) battery. Red may run to (+) battery or starter. Mount circuit breaker as close to battery as possible.

WARNING:
ALWAYS MOUNT CIRCUIT BREAKER AS CLOSE TO THE BATTERY AS POSSIBLE. (NOTE: WIRE BETWEEN BATTERY AND CIRCUIT BREAKER IS UNPROTECTED AND SHOULD BE CAREFULLY ROUTED TO AVOID A SHORT CIRCUIT).



www.vintageair.com

Operation of Controls

On Gen IV systems with three lever/knob controls, the temperature control toggles between heat and A/C operations. To activate A/C, move the temperature lever/knob all the way to cold and then back it off to the desired vent temperature. For heat operation, move the temperature lever/knob all the way to hot and then adjust to the desired vent temperature. The blower will momentarily change speed, each time you toggle between operations, to indicate the change.

Blower Speed

This lever/knob controls blower speed, from OFF to HI.

Mode Control

This lever/knob controls the mode positions, from DEFROST to FLOOR to DASH, with a blend in between.

Temperature Control

This lever/knob controls the temperature, from HOT to COLD.

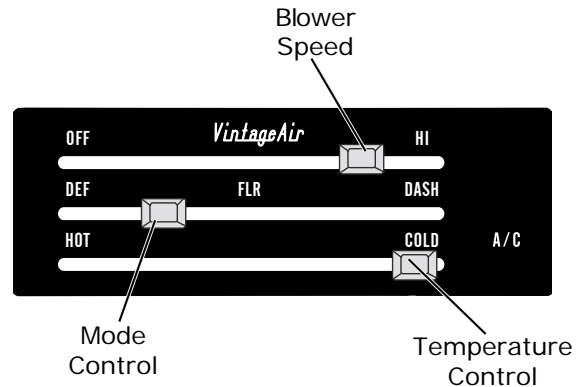

A/C Operation

Blower Speed

Adjust to desired speed.

Mode Control

Adjust to desired mode position (DASH position recommended).

Temperature Control

For A/C operation, adjust to coldest position to engage compressor (Adjust between HOT and COLD to reach desired temperature).



Heat Operation

Blower Speed

Adjust to desired speed.

Mode Control

Adjust to desired mode position (FLOOR position recommended).

Temperature Control

For maximum heating, adjust to hottest position (Adjust between HOT and COLD to reach desired temperature).



Defrost/De-fog Operation

Blower Speed

Adjust to desired speed.

Temperature Control

Adjust to desired temperature.

Mode Control

Adjust to DEFROST position for maximum defrost, or between FLOOR and DEFROST positions for a bi-level blend (Compressor is automatically engaged).





www.vintageair.com

Troubleshooting Guide

Symptom	Condition	Checks	Actions	Notes
1a. Blower stays on high speed when ignition is on.	No other functions work.	Check for damaged pins or wires in control head plug.	Verify that all pins are inserted into plug. Ensure that no pins are bent or damaged in ECU.	Loss of ground on this wire renders control head inoperable.
	All other functions work.	Check for damaged ground wire (white) in control head harness.	Verify continuity to chassis ground with white control head wire at various points.	
		Check for damaged blower switch or potentiometer and associated wiring.	See blower switch check procedure.	
1b. Blower stays on high speed when ignition is on or off.		Unplug 3-wire BSC control connector from ECU. If blower shuts off, ECU is either improperly wired or damaged.	Be sure the small, 20 GA white ground wire is connected to the battery ground post. If it is, replace the ECU.	No other part replacements should be necessary.
		Unplug 3-wire BSC control connector from ECU. If blower stays running, BSC is either improperly wired or damaged.	Check to ensure that no BSC wiring is damaged or shorted to vehicle ground. The BSC operates the blower by ground side pulse width modulation switching. The positive wire to the blower will always be hot. If the "ground" side of the blower is shorted to chassis ground, the blower will run on HI.	
		Replace BSC (This will require removal of evaporator from vehicle).		
2. Compressor will not turn on (All other functions work).	System is not charged.	System must be charged for compressor to engage.	Charge system or bypass pressure switch.	Danger: Never bypass safety switch with engine running. Serious injury can result.
		Check for faulty A/C potentiometer or associated wiring (not applicable to 3-pot controls).	Check continuity to ground on white control head wire. Check for 5V on red control head wire.	
	System is charged.	Check for disconnected or faulty thermistor.	Check 2-pin connector at ECU housing.	Disconnected or faulty thermistor will cause compressor to be disabled.
3. Compressor will not turn off (All other functions work).		Check for faulty A/C potentiometer or associated wiring.	Repair or replace pot/control wiring.	Red wire at A/C pot should have approximately 5V with ignition on. White wire will have continuity to chassis ground. White/Blue wire should vary between 0V and 5V when lever is moved up or down.
		Check for faulty A/C relay.	Replace relay.	



www.vintageair.com

Troubleshooting Guide (Cont.)

Symptom	Condition	Checks	Actions	Notes
4.	Works when engine is not running; shuts off when engine is started (typically early Gen IV, but possible on all versions).	Noise interference from either ignition or alternator.	Install capacitors on ignition coil and alternator. Ensure good ground at all points. Relocate coil and associated wiring away from ECU and ECU wiring. Check for burned or loose plug wires.	Ignition noise (radiated or conducted) will cause the system to shut down due to high voltage spikes. If this is suspected, check with a quality oscilloscope. Spikes greater than 16V will shut down the ECU. Install a radio capacitor at the positive post of the ignition coil (see radio capacitor installation bulletin). A faulty alternator or worn out battery can also result in this condition.
	System will not turn on, or runs intermittently.	Will not turn on under any conditions.	Check for positive power at heater valve green wire and blower red wire. Check for ground on control head white wire.	
		Verify battery voltage is greater than 10 volts and less than 16.	Verify proper meter function by checking the condition of a known good battery.	
5.	No mode change at all.	Check for damaged mode switch or potentiometer and associated wiring.		Typically caused by evaporator housing installed in a bind in the vehicle. Be sure all mounting locations line up and don't have to be forced into position.
	Partial function of mode doors.	Check for obstructed or binding mode doors.		
		Check for damaged stepper motor or wiring.		
6.	Battery voltage is at least 12V.	Check for at least 12V at circuit breaker.	Ensure all system grounds and power connections are clean and tight.	System shuts off blower at 10V. Poor connections or weak battery can cause shutdown at up to 11V.
	Blower turns on and off rapidly.	Battery voltage is less than 12V.	Charge battery.	
7.	Erratic functions of blower, mode, temp, etc.	Check for damaged switch or pot and associated wiring.	Repair or replace.	
8.	When ignition is turned on, blower momentarily comes on, then shuts off. This occurs with the blower switch in the OFF position.	This is an indicator that the system has been reset. Be sure the red power wire is on the battery post, and not on a switched source. Also, if the system is pulled below 7V for even a split second, the system will reset.	Run red power wire directly to battery.	



www.vintageair.com

Packing List: Evaporator Kit (564176)

No.	Qty.	Part No.	Description
1.	1	764172	Gen IV Evaporator Sub Case
2.	1	785176	Accessory Kit

Checked By: _____
 Packed By: _____
 Date: _____

1

Gen IV Evaporator
Sub Case
764172

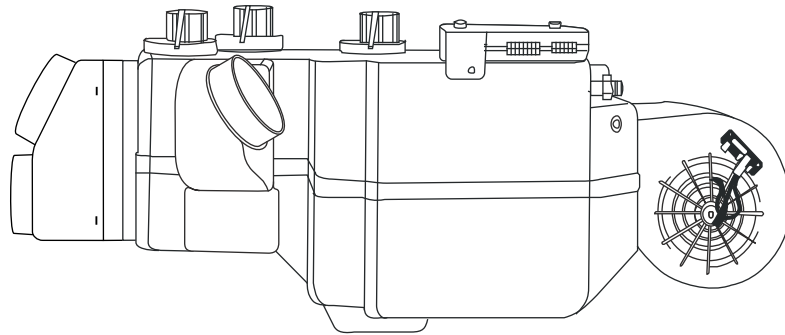

2



Accessory Kit
785176

**NOTE: Images may not depict actual parts and quantities.
 Refer to packing list for actual parts and quantities.**